

Classic Series

Proven. Quality. Customisable

BLAIZE 18W LED 300x300mm

Square Panel Light

The BLAIZE 300x300 LED Panel Light is at the leading edge of commercial lighting. Suitable for surface mounting, or recessed or suspended. Eliminate maintenance costs, and enjoy a high efficiency light source. Dimmable Driver available. This LED panel light is a brilliant light that offers high performance combined with affordability and sustainability.

Verified by Techlume Australia on 22/03/2023



SPECIFICATIONS

Material Specifications

| | |
|---------------------------|---|
| Material | White Aluminium Frame. PMMA |
| Dimensions | 295mm x 295mm x 12mm |
| Ingress Protection | IP44 |
| Weight | 2.2Kg |
| Options | Surface Mount, Plaster Recess & Suspension Kits |
| Warranty | 5 Year Replacement |

Electrical Specifications

| | |
|--------------------------|-----------------------------------|
| Power Supply | Non-Dimmable Lifud Remote Driver |
| System Watts | 18.2W |
| Connection Method | Australian 2-Pin Plug & 1.0m Lead |
| Input Voltage | 240V |

Optic Specifications

| | |
|--------------------------------------|-------------------------------|
| Light Source | Epistar 18W, Edge lit |
| Correlated Colour Temperature | Tri-colour: 3000K/4000K/5000K |
| Nominal Lumens | 1,678lm |
| Efficacy | 92.1lm/W |
| Beam Angle | 120° |
| CRI | Ra 81 |
| Colour Deviation | SDCM<3 |
| Reported L70 (Hours) | > 54,000 Hrs |

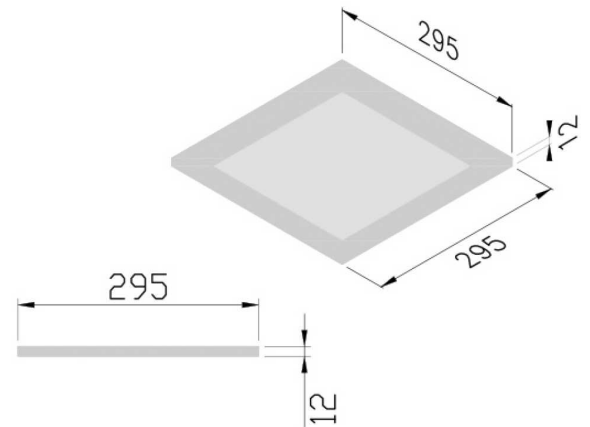

VARIATIONS

| | |
|---------------|---|
| LC7024 | BLAIZE 18W LED Panel Light, 300x300, White, 120°, Non-Dim, 3000K, 1,678lm |
| LC7025 | BLAIZE 18W LED Panel Light, 300x300, White, 120°, Non-Dim, 4000K, 1,678lm |
| LC7026 | BLAIZE 18W LED Panel Light 300x300, White, 120°, Non-Dim, Tri-colour, 1,678lm |