

Classic Series

Proven. Quality. Customisable

BLAIZE 30W

Square Panel Light 600x600

The BLAIZE LED Panel Light series is at the leading edge of commercial lighting. BLAIZE 30W LED 600x600 Light Panels are a revolutionary replacement for traditional fluorescent tubes. Our LED light panels use a high brightness quality LED chip modules as a light source which consumes up to 70% less energy. Designed for offices, hotels, meeting rooms, home interiors, school classrooms etc. Dimmable Drivers available. Suitable for surface mounting, recessed or suspended.

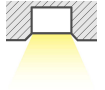

IP44



Flicker Free



SPECIFICATIONS

Material Specifications

Material	White Aluminium Frame. PMMA
Dimensions	595mm (L) x 595mm (W) x 12mm (D)
Ingress Protection	IP44
Options	Surface Mount, Plaster Recess & Suspension Kits
Weight	3.2Kg
Warranty	5 Year Replacement

Electrical Specifications

Power Supply	Non-Dimmable Boke 30W Remote Driver
Input Voltage	240V
Options	DALI Available
Output Voltage	25V-42V (Driver output) Constant Current
Connection Method	Australian 2-Pin Plug & 1.2m Lead
Operating Temperature (Ta)	-20°C to +45°C

Optic Specifications

Light Source	30W Epistar SMD 144 pcs, 2-side Edge lit
Nominal Lumens	3685lm (4000K)
CRI	80Ra
Beam Angle	120°
Colour Deviation	SDCM ≤ 4
Reported L70 (Hours)	> 54,000 Hrs

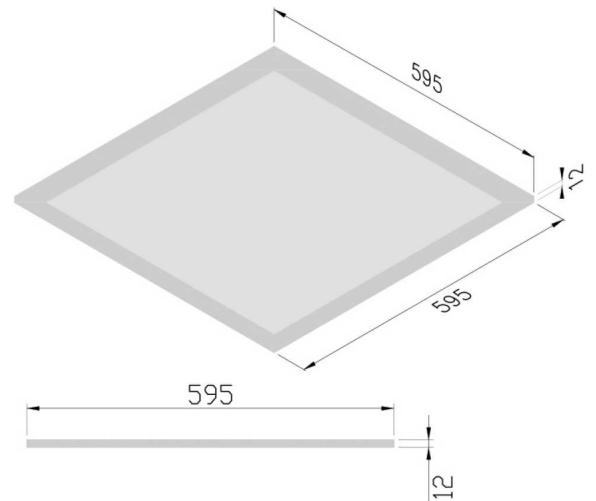

VARIATIONS

LC7162	BLAIZE 30W 600x600 Panel Light, White, Non-Dim, 3000K
LC7163	BLAIZE 30W 600x600 Panel Light, White, Non-Dim, 4000K