

# CREST 18W

## UGR<19 Panel Light 600x300

**Classic Series**

Proven. Quality. Customisable

The CREST 18W Panel Light 600x300 is at the leading edge of commercial lighting. Suitable for surface mounting or recessed or suspended. Eliminate maintenance costs and enjoy a high-efficiency light source. DALI Dimmable driver is available. This LED panel light is a brilliant light that offers high performance combined with affordability and sustainability.

Verified by Techlume Australia on 25/08/2023



### SPECIFICATIONS

#### Material Specifications

|                           |   |
|---------------------------|---|
| <b>Material</b>           | White Aluminium Frame. PMMA                     |
| <b>Dimensions</b>         | 295mm x 595mm x 12mm                            |
| <b>Ingress Protection</b> | IP44  |
| <b>Weight</b>             | 2.2Kg   |
| <b>Options</b>            | Surface Mount, Plaster Recess & Suspension Kits |
| <b>Warranty</b>           | 5 Year Replacement                              |

#### Electrical Specifications

|                                   |                                   |
|-----------------------------------|-----------------------------------|
| <b>Power Supply</b>               | Non-Dimmable Boke Remote Driver   |
| <b>System Watts</b>               | 17.4W                             |
| <b>Input Voltage</b>              | 240V                              |
| <b>Connection Method</b>          | Australian 2-Pin Plug & 1.2m Lead |
| <b>Operating Temperature (Ta)</b> | -20°C to +45°C                    |

#### Optic Specifications

|                                |                          |
|--------------------------------|--------------------------|
| <b>Light Source</b>            | Epistar, 2-side Edge lit |
| <b>Nominal Lumens</b>          | 2,266lm                  |
| <b>Efficacy</b>                | 130.4 lm/W               |
| <b>CRI</b>                     | Ra 82                    |
| <b>Beam Angle</b>              | 80°                      |
| <b>Colour Deviation</b>        | SDCM ≤ 3                 |
| <b>Rated Lifetime (L70B20)</b> | 50,000 Hrs               |

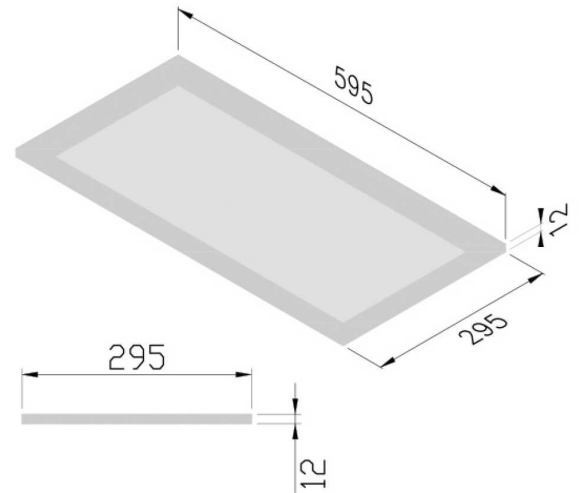

### VARIATIONS

|                |  |
|----------------|--|
| <b>LC7190</b>  | CREST 18W LED Anti-Glare Panel Light 600x300, White, 80°, Non-Dim, 4000K, 2,266lm  |
| <b>LC7190D</b> | CREST 18W LED Anti-Glare Panel Light 600x300, White, 80°, DALI Dim, 4000K, 2,266lm |