

**Classic Series**

Proven. Quality. Customisable

# CREST 26W

## UGR<19 Panel Light 600x300

The CREST 26W Panel Light 600x300 is at the leading edge of commercial lighting. Suitable for surface mounting or recessed or suspended. Eliminate maintenance costs and enjoy a high efficiency light source. Dimmable driver available. This LED panel light is a brilliant light that offers high performance combined with affordability and sustainability.



### SPECIFICATIONS

#### Material Specifications

<b>Material</b>	White Aluminium Frame. PMMA
<b>Dimensions</b>	595mm (L) x 295mm (W) x 10mm (D)
<b>Ingress Protection</b>	IP44
<b>Weight</b>	2.2Kg
<b>Options</b>	Surface Mount, Plaster Recess & Suspension Kits
<b>Warranty</b>	5 Year Replacement

#### Electrical Specifications

<b>Power Supply</b>	Non-Dimmable Boke Remote Driver
<b>Connection Method</b>	Australian 2-Pin Plug & 1.2m Lead
<b>Input Voltage</b>	240V
<b>Operating Temperature (Ta)</b>	-20°C to +45°C

#### Optic Specifications

<b>Light Source</b>	Epistar, 2-side Edge lit
<b>Nominal Lumens</b>	2322lm
<b>CRI</b>	80Ra
<b>Calculated L70 (Hours)</b>	>170,000 Hrs
<b>Calculated L80 (Hours)</b>	>110,000 Hrs
<b>Calculated L90 (Hours)</b>	>53,000 Hrs

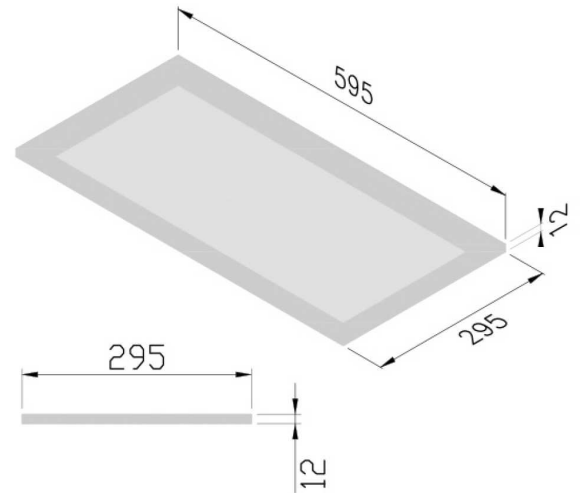

### VARIATIONS

<b>LC7131</b>	CREST 26W LED Anti-Glare Panel Light 600x300, White, 100°, Non-Dim, 4000K
<b>LC7131D</b>	CREST 26W LED Anti-Glare Panel Light 600x300, White, 100°, DALI Dim, 4000K