

ZERO Dome 2W

Exterior Inground Light

diomede

let there be light

Ground recessed luminaire with Stainless Steel 316 body, tempered serigraph glass and diffused glass. Premium Quality, Italian Made product.

Protection against water ingress is guaranteed by the internal resin-filling process of the body, which completely seals the LED chip from moisture. A product designed as a solution for flush installation in >walkable floors or walls using its recessed box.

24Vdc remote power supply to be ordered separately.

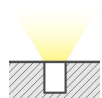

IP67

MADE IN ITALY

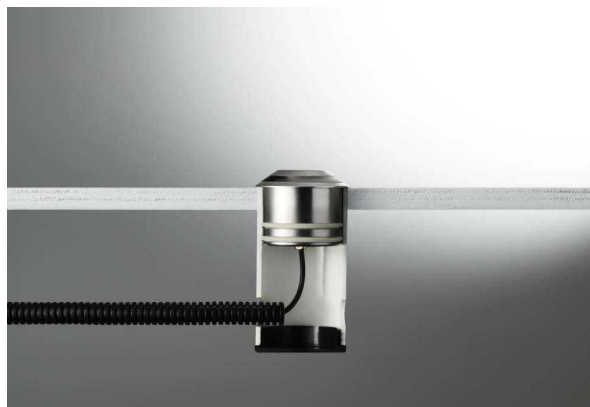

SPECIFICATIONS

Material Specifications

Material	SS316, Tempered Glass
Dimensions	65mm (Dia) x 11mm(H, above ground)

Cutout

Ingress Protection	IP67
Impact Rating	IK07
Accessories	Recessed Box Included
Warranty	5 Year Replacement

Electrical Specifications

Connection Method	200mm 2-core tail
Power Supply	IP67 Remote Driver, Sold Separately
Input Voltage	24V

Optic Specifications

Light Source	2W CREE LED
Optics	Radial Emission
CRI	80Ra
Reported L70 (Hours)	>54,000 Hrs

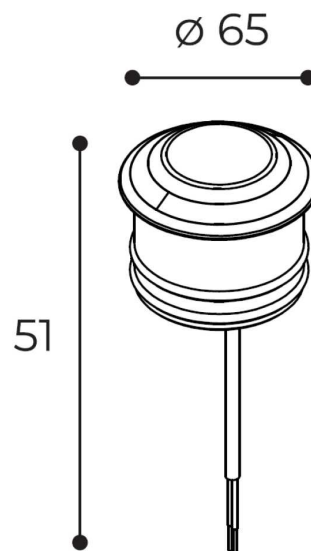

VARIATIONS

900112181	ZERO Dome 2W Inground Light 24V, 360°, 3000K, 52lm
900112182	ZERO Dome 2W Inground Light 24V, 180°, 3000K