

Lifestyle Series

Style. Attitude. Luxury

FERNHURST 20W

Modern Post Top Light

The FERNHURST 20W LED Post Top Light is a Classic A Shape Design, providing you with an amazing architectural solution. The engineered anti-glare design gives a soft, subtle light. Designed for perfect heat dissipation. Silicone rubber seal assists in making the FERNHURST dust proof.

It has a vertical post-top mounting. Suitable for LED Outdoor applications including city parks, community precincts, urban landscapes and pedestrian security. Driver cannot be remote mounted. Designed for a 2.5m-4m pole height. Pole available separately.



SPECIFICATIONS

Material Specifications

Material	Aluminium Die-Cast Housing, Aluminium Reflector
Dimensions	450mm (Dia) x 509mm (H)
Spigot Size	90mm (Dia)
Accessories	65mm Reducing Sleeve (included)
Ingress Protection	IP65
Impact Rating	IK08
Weight	6.4Kg
Warranty	5 Year Replacement

Electrical Specifications

Power Supply	Meanwell HLG Series
Input Voltage	240V
Connection Method	Hard-Wired
Dimming	Non-Dim

Optic Specifications

Light Source	20W Bridgelux LED
Delivered Lumens	1942lm
Beam Angle	Symmetrical
CRI	82Ra
Colour Deviation	SDCM ≤ 3
Reported L70 (Hours)	> 45,000 Hrs

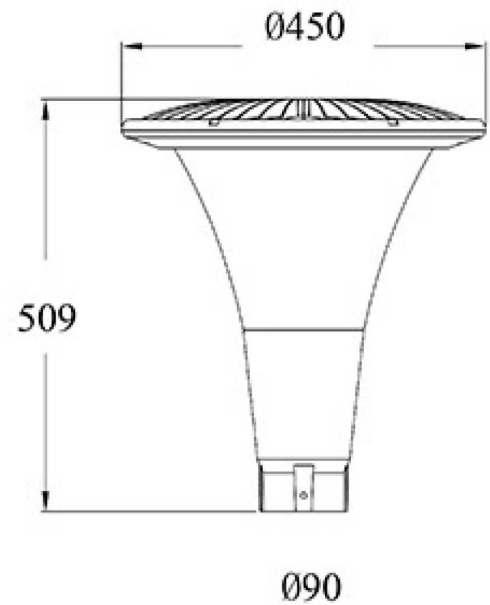

VARIATIONS

LC3181	FERNHURST 20W Post Top Light, Black, Non-Dim, 4000K
---------------	---