

KINGSTON 150W

Streetlight w. PE Cell

Classic Series

Proven. Quality. Customisable

The KINGSTON 150W Roadway Lighting Series is powered by the Crystal OpticLED platform, and features innovative thermal management design, offering exceptional performance and value. This versatile luminaire can be tailored to the unique specifications of each project. Tool Free Opening Clip, allowing for Top Opening Easy Maintenance. The KINGSTON Streetlight Series is fitted with knife switch safety feature to cut off power supply when the device is open.

Verified by Techlume Australia on 12/04/2023

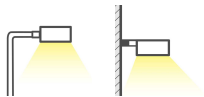

IP66



SPECIFICATIONS

Material Specifications

Housing	High Pressure Die-Cast Aluminium Alloy, Clear Tempered Glass
Finish	Polyester Powder Coat, Signal Black
Dimensions	683mm(L) x 260mm(W) x 109mm(H)
Spigot Size	60mm
Ingress Protection	IP66
Impact Rating	IK10
Weight	6.0kg
Mounting Height	8m - 10m
Warranty	5 Year Replacement

Electrical Specifications

Power Supply	Integrated Driver
System Watts	148.0W
Input Voltage	240VAC, 50/60Hz
Operating Temperature (Ta)	-20°C to + 55°C

Optic Specifications

Light Source	LED SMD 5050
Delivered Lumens	22,078lm
Efficacy	149lm/W
CRI	> 70Ra
Reported L70 (Hours)	> 54,000 Hrs
Calculated L90 (Hours)	49,000 Hrs
Calculated L70 (Hours)	79,000 Hrs

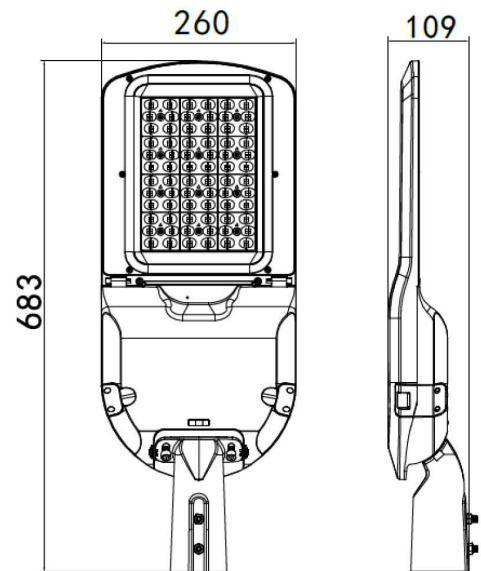

VARIATIONS

LC6160-T2-PE	KINGSTON 150W Streetlight w. PE Cell, Signal Black, T2, 4000K, 22,078lm
LC6160-T3-PE	KINGSTON 150W Streetlight w. PE Cell, Signal Black, T3, 4000K, 22,078lm
LC6160-T4-PE	KINGSTON 150W Streetlight w. PE Cell, Signal Black, T4, 4000K, 22,078lm
LC6161-T3-PE	KINGSTON 150W Streetlight w. PE Cell, Signal Black, T3, 3000K