

Classic Series

Proven. Quality. Customisable

KINGSTON 200W

Architectural Streetlight

The KINGSTON 200W Roadway Lighting Series is powered by the Crystal OpticLED platform, and features innovative thermal management design, offering exceptional performance and value. This versatile luminaire can be tailored to the unique specifications of each project. Tool Free Opening Clip, allowing for Top Opening Easy Maintenance. The KINGSTON Streetlight Series is fitted with knife switch safety feature to cut off power supply when the device is open.



SPECIFICATIONS

Material Specifications

Housing	High Pressure Die-Cast Aluminium Alloy, Clear Tempered Glass
Finish	Polyester Powder Coat, Signal Black
Dimensions	683mm(L) x 260mm(W) x 109mm(H)
Spigot Size	60mm
Ingress Protection	IP66
Impact Rating	IK10
Weight	6.0kg
Mounting Height	8m - 10m
Warranty	5 Year Replacement

Electrical Specifications

Power Supply	Integrated Inventronics Driver
System Watts	197-199W
Input Voltage	240VAC, 50/60Hz
Options	Dimming System/ PE Cell/ NEMA Socket
Operating Temperature (Ta)	-20°C to +55°C

Optic Specifications

Light Source	LED SMD 5050
Efficacy	Up to 149lm/W
CRI	Ra 79
Calculated L90 (Hours)	49,000 Hrs
Calculated L70 (Hours)	79,000 Hrs

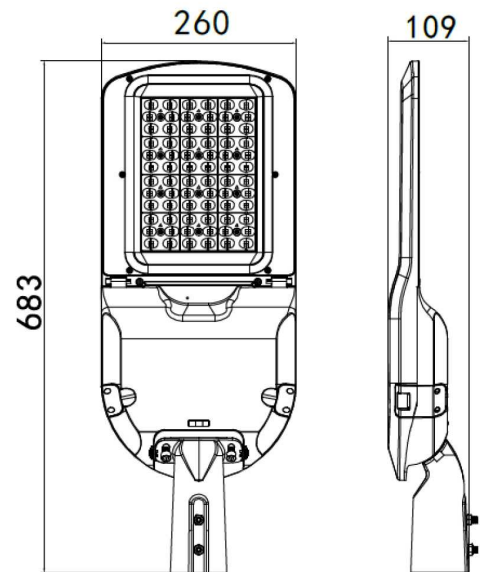

VARIATIONS

LC6170-T1	KINGSTON 200W Streetlight, Signal Black, T1, 4000K, 28,544lm
LC6170D-T1	KINGSTON 200W Streetlight, Signal Black, T1, DALI, 4000K, 28,544lm
LC6170-T2	KINGSTON 200W Streetlight, Signal Black, T2, 4000K, 28,544lm
LC6170D-T2	KINGSTON 200W Streetlight, Signal Black, T2, DALI, 4000K, 28,544lm
LC6170-T3	KINGSTON 200W Streetlight, Signal Black, T3, 4000K, 28,738lm
LC6170D-T3	KINGSTON 200W Streetlight, Signal Black, T3, DALI, 4000K, 28,738lm
LC6170-T4	KINGSTON 200W Streetlight, Signal Black, T4, 4000K, 30,838lm
LC6170D-T4	KINGSTON 200W Streetlight, Signal Black, T4, DALI, 4000K, 30,838lm

LC6170-T5 KINGSTON 200W Streetlight, Signal Black, T5, 4000K, 30,838lm
LC6170D-T5 KINGSTON 200W Streetlight, Signal Black, T5, DALI, 4000K, 30,838lm

Classic Series

Proven. Quality. Customisable