

LITHO 9W

Exterior Can Light IP65

Classic Series

Proven. Quality. Customisable

The LITHO Surface Mount Can Light, made from cast aluminium with a sandy anthracite powder coated finish, is perfect for walkways, hallways, amenities, under eaves and where recessed downlights aren't suitable. Designed to be compact and easy to install, the lightweight IP65 can light is suitable for use in a number of external applications where dust and water are present. The routed line details in the shell gives it that touch of styling while maintaining a minimalist aesthetic.

Verified by Techlume Australia on 25/08/2023



SPECIFICATIONS

Material Specifications

Colour	Sandy Anthracite
Dimensions	100mm(Dia) x 126mm(D)
Ingress Protection	IP65
Impact Rating	IK08
Warranty	5 Year Replacement

Electrical Specifications

Power Supply	500mA Integral Driver, Non-Dim
System Watts	10.5W
Input Voltage	240V
Connection Method	Hard Wired
Operating Temperature (Ta)	-20°C to +50°C

Optic Specifications

Light Source	9W Sharp LED
Delivered Lumens	1,134lm
Efficacy	107.7lm/W
Beam Angle	55° Reflector
CRI	84Ra
Colour Deviation	SDCM ≤ 3
Reported L70 (Hours)	> 54,000 Hrs

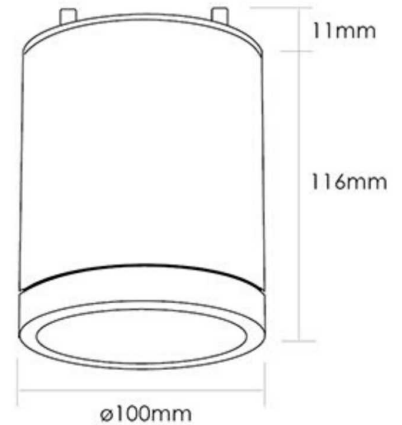

VARIATIONS

LC4108	LITHO 9W Exterior Surface Mount Can Light, Sandy Anthracite, 55°, Non-Dim, 3000K, 1,134lm
---------------	---