

LITHO 9W

Round Exterior Ceiling Light

Classic Series

Proven. Quality. Customisable

The LITHO Surface Mount Can Light, made from cast aluminium with a sandy anthracite powder coated finish, is perfect for walkways, hallways, amenities, under eaves and where recessed downlights aren't suitable. Designed to be compact and easy to install, the lightweight IP65 can light is suitable for use in a number of external applications where dust and water are present. The routed line details in the shell gives it that touch of styling while maintaining a minimalist aesthetic.

Verified by Techlume Australia on 25/08/2023



SPECIFICATIONS

Material Specifications

| | |
|--------------------|-----------------------|
| Colour | Sandy Anthracite |
| Dimensions | 100mm(Dia) x 126mm(D) |
| Ingress Protection | IP65 |
| Impact Rating | IK08 |
| Warranty | 5 Year Replacement |

Electrical Specifications

| | |
|----------------------------|--------------------------------|
| Power Supply | 500mA Integral Driver, Non-Dim |
| System Watts | 10.5W |
| Input Voltage | 240V |
| Connection Method | Hard Wired |
| Operating Temperature (Ta) | -20°C to +50°C |

Optic Specifications

| | |
|----------------------|---------------|
| Light Source | 9W Sharp LED |
| Delivered Lumens | 1,134lm |
| Efficacy | 107.7lm/W |
| Beam Angle | 55° Reflector |
| CRI | 84Ra |
| Colour Deviation | SDCM ≤ 3 |
| Reported L70 (Hours) | > 54,000 Hrs |

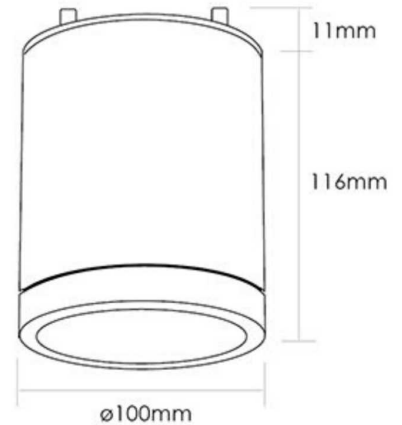

VARIATIONS

| | |
|--------|---|
| LC4108 | LITHO 9W Exterior Surface Mount Can Light, Sandy Anthracite, 55°, Non-Dim, 3000K, 1,134lm |
|--------|---|