

NEO-G Maxi 11.5W

IP68 Ground Light

Lifestyle Series

Style. Attitude. Luxury

The NEO-G LED Ground Lights are marine grade quality, covered with a five year warranty. Capable of being completely submerged, these lights are great for pools, driveways, ponds and decks. Can be installed in concrete or gravel. 8mm tempered glass lens supports 2000kg drive over, manufactured with high quality anodized aluminium outer casing. These LED recessed fittings have a stainless steel (316L) front face protecting them from water including salt water and general corrosion. Driver sold separately. This product is not dimmable. Now featuring a honeycomb lens for reduced glare.

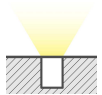

IP68



Not Dimmable



SPECIFICATIONS

Material Specifications

Housing	Die-cast aluminium with tempered glass and 316 stainless steel cover
Ingress Protection	IP68
Impact Rating	IK10
Dimensions	Diameter 90mm ø Depth 119mm
Cutout	78mm ø (without canister)
Accessories	Installation Blockout, 103mm x 180mm Plastic Casing
Warranty	5 Year Replacement

Electrical Specifications

Power Supply	IP67 Driver, Sold Separately
Input Voltage	20V - 24V
Connection Method	2-core double-insulated cable
Max Distance From Power Supply	10 metres recommended

Optic Specifications

Light Source	11.5W CREE LED
Optics	30° or 60°
Delivered Lumens	1000lm
CRI	90Ra
Reported L70 (Hours)	> 54,000 Hrs
UGR	Honeycomb Lens

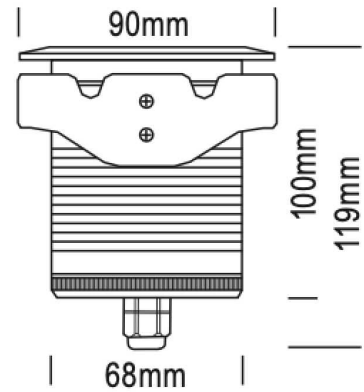

VARIATIONS

LC5091-30	NEO-G Maxi 11.5W Ground Light, 30°, 3000K
LC5091-60	NEO-G Maxi 11.5W Ground Light, 60°, 3000K