

Lifestyle Series

Style. Attitude. Luxury

SNITCH 1.5W

Handrail Light

The SNITCH 1.5W LED Handrail Lights are marine grade quality, covered with a five-year warranty. Designed for architectural lighting and for safe movement in public spaces. These LED recessed fittings have a stainless steel (316L) front face protecting them from water including saltwater and general corrosion. Suitable for tubes with a diameter of 48-60mm, and tube wall thickness 1-2mm. Asymmetrical 30°x60° optic, with spring for fast recessed installation. The ideal spacing is 600mm apart, to avoid a patchy light spread. Constant Voltage, designed for an input of 12-24V.



IP67



SPECIFICATIONS

Material Specifications

Housing	316 Stainless Steel
Mounting	Recessed in Handrail Tube, ideal spacing 600mm apart.
Dimensions	28.5mm (Dia) x 28mm (H)
Cutout	27mm (Dia)
Weight	0.48kgs
Ingress Protection	IP67
Impact Rating	IK06
Warranty	5 Year Replacement

Electrical Specifications

Power Supply	Integrated DC-DC Converter. IP67 External, Sold Separately.
Connection Method	1PC teflon cable 0.25M 2*0.3mm square
Input Voltage	12-24VDC
Max. Loading	20 units per power feed
Max Distance From Power Supply	10 metres recommended

Optic Specifications

Light Source	1.5W CREE LED
Beam Angle	30°x60° Asymmetric
CRI	> 80Ra
Reported L70 (Hours)	> 50,000 Hrs

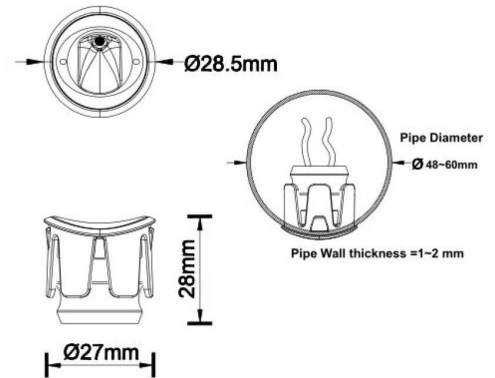

VARIATIONS

LC4760	SNITCH 1.5W LED Handrail Light, SS316, 30°x60°, 3000K, 76lm
LC4761	SNITCH 1.5W LED Handrail Light, SS316, 30°x60°, 4000K, 95lm