

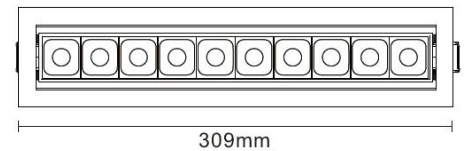

## Product Overview

<b>Product Name / Code</b>	LINX 22W Linear Downlight Fixed - LC4451
<b>Description</b>	4000K, IP40, 40°, White/Black Insert, Phase Dim
<b>Manufacturer</b>	Decrolux Lighting Pty Ltd

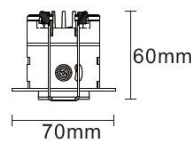

## Laboratory and Equipment

<b>System Name / Model</b>	LabSpion / Freedom VIS (Custom Viso)
<b>Manufacturer / Serial Number</b>	Ibsen Photonics, Denmark / 2417457569
<b>Sensor Name</b>	LabSensor Model2
<b>Sensor Serial Number / Calibration Date</b>	3430823524 / 7/12/2022

## Measurement Details

<b>Test Date and Time</b>	4/05/2023 10:20:22 AM
<b>Operator</b>	Johnny Elmer
<b>C-Planes Measured</b>	36
<b>Measurement Resolution</b>	10°
<b>Measurement Distance</b>	464.4cm
<b>Measurement Number</b>	VFR-230504-0075-MS
<b>Tracking Link</b>	<a href="http://www.visosystems.com/tracking/?id=VT230510-002380">http://www.visosystems.com/tracking/?id=VT230510-002380</a>



## Performance

<b>Total Lumen Output</b>	1889 lm
<b>Light Efficiency</b>	83 Lumen/Watt
<b>Peak (cd)</b>	4031 cd
<b>Nominal Power</b>	22.7 W
<b>Input Voltage</b>	240 V
<b>Frequency of Input Power</b>	60 Hz
<b>Power Factor</b>	0.98
<b>Warm-up (stabilisation) Time</b>	Lamp stabilized in 1 hour 1 min
<b>Warm-up Variation</b>	-8.5

## Spectral Power Distribution (SPD)

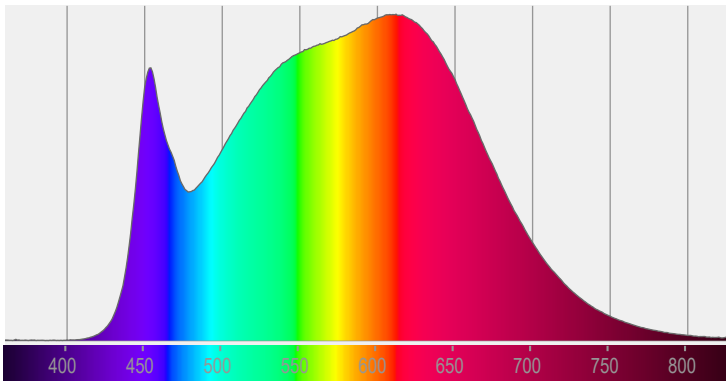

## Input Power Curve

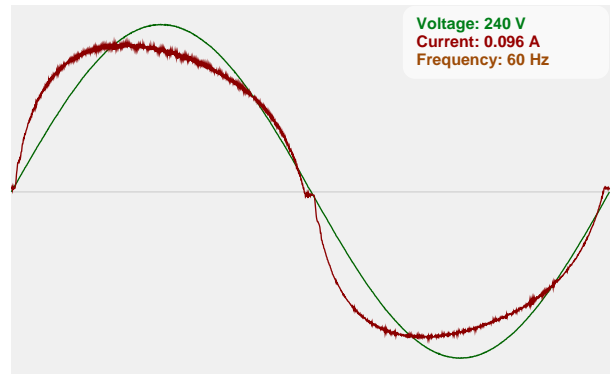

## Optic Specifications

<b>Correlated Colour Temperature, Target</b>	4000K
<b>Correlated Colour Temperature, Measured</b>	3869K
<b>Colour Rendering Index</b>	CRI 90.7
<b>R9 Value</b>	R9 = 54.4
<b>Colour Rendering TM30-18</b>	R <sub>f</sub> 88.7 - R <sub>g</sub> 94.8
<b>Colour Quality Scale</b>	CQS = 90.6
<b>Beam Angle</b>	40°

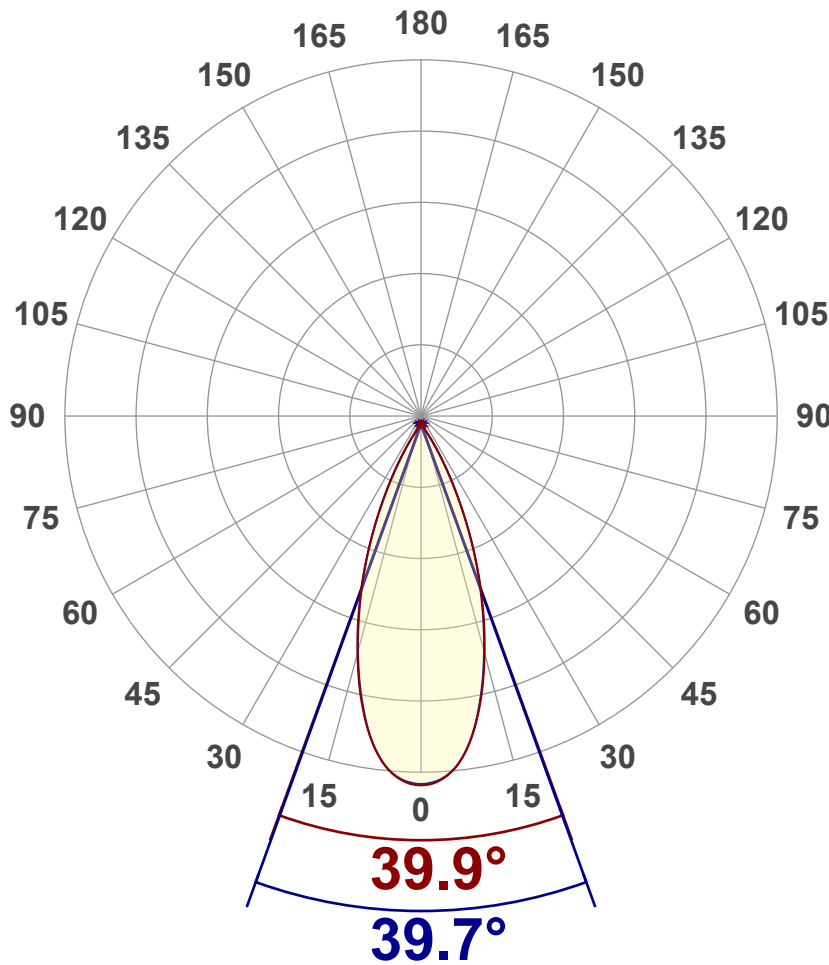

**Angular Distribution – 0° / 90° Plane**

**Main Values**

<b>Total Lumen Output</b>	1889 lm
<b>Lumen Up% / Down%</b>	0.26 % / 99.74%
<b>Peak Intensity</b>	4031 cd
<b>Beam Angle (50%)</b>	40°
<b>Beam Angle (90%)</b>	39.7°
<b>Beam Angle (10%)</b>	40°

**Cut-off Angle**

<b>Average 2.5%</b>	75.8°
---------------------	-------

**Field Angle**

<b>Average 10%</b>	65.8°
--------------------	-------

**Intensity Ratio**

<b>In 120° Cone</b>	99.7%
<b>In 90° Cone</b>	99.6%

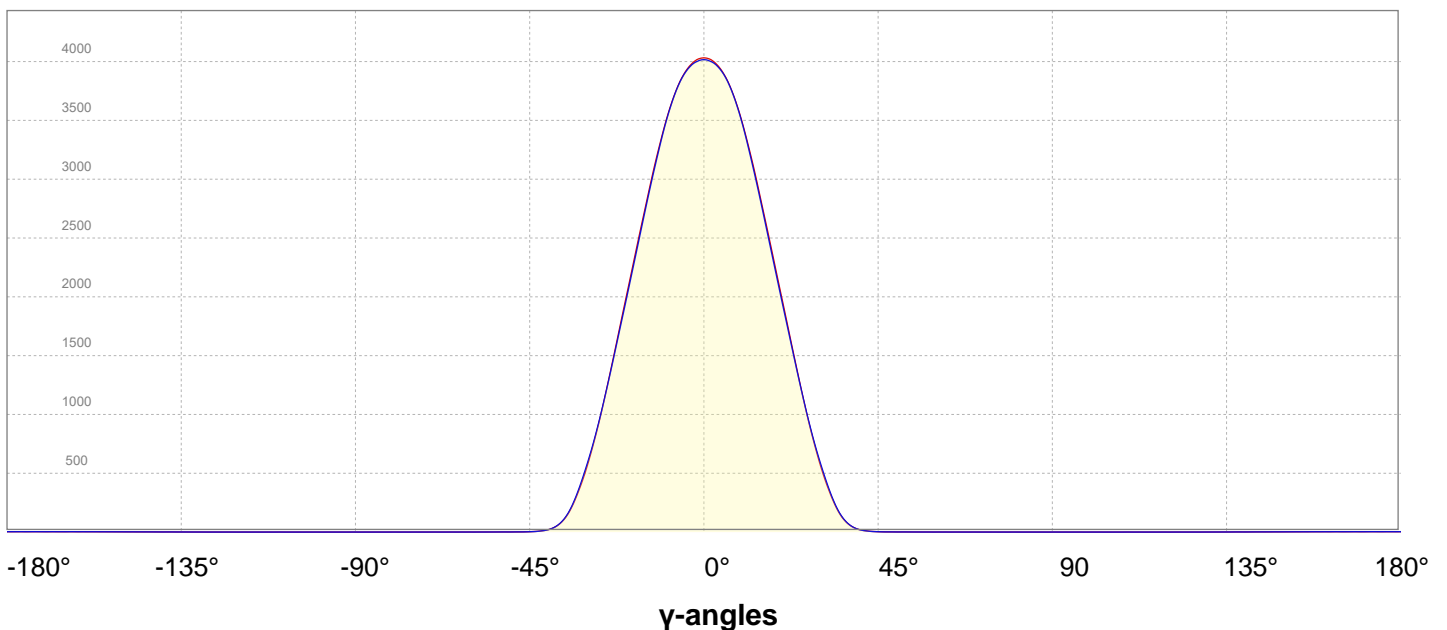
**C000-C180**
**C090-C270**
**Linear Distribution Diagram – Intensity (candela) vs γ-angle**

### Beam Details

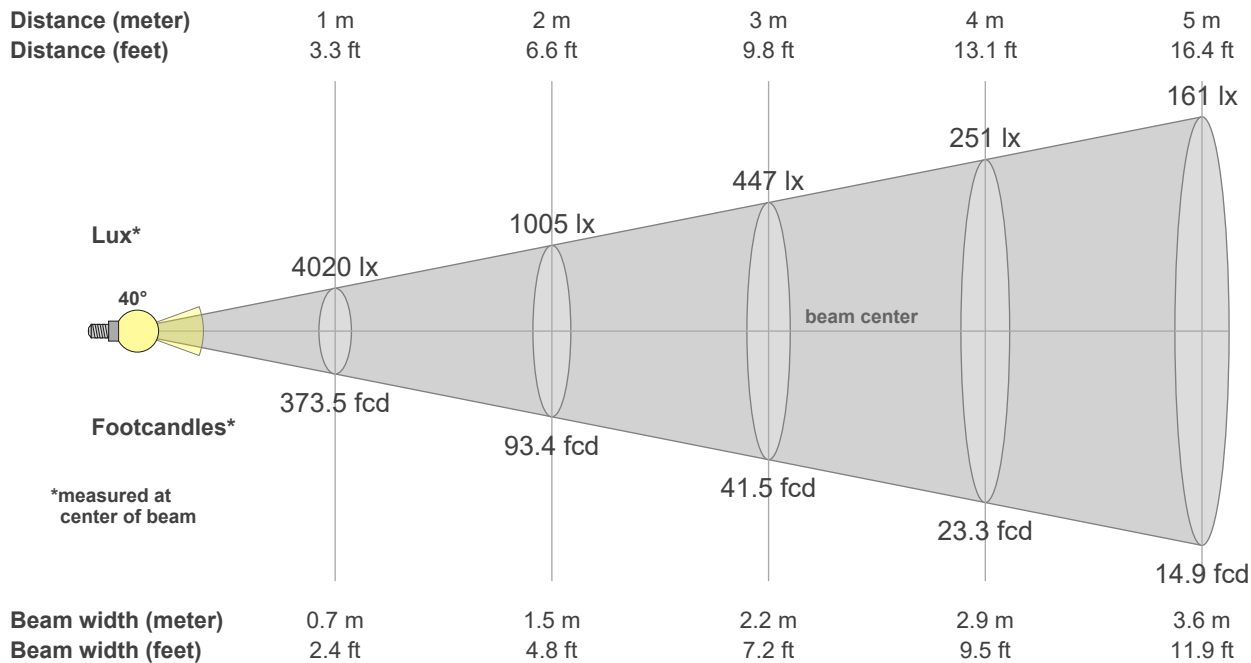

### Beam intensities from 1 – 20m

1	2	3	4	5	6	7	8	9	10	11	12	13	14	15	16	17	18	19	20	m
3.3	6.6	9.8	13.1	16.4	19.7	23	26.2	29.5	32.8	36.1	39.4	42.7	45.9	49.2	52.5	55.8	59.1	62.3	65.6	ft
4020	1005	447	251	161	112	82	63	50	40	33	28	24	21	18	16	14	12	11	10	lux
373.5	93.4	41.5	23.3	14.9	10.4	7.6	5.8	4.6	3.7	3.1	2.6	2.2	1.9	1.7	1.5	1.3	1.2	1	0.9	fc

### Intensities in 0° c-plane

0°	2°	4°	6°	8°	10°	12°	14°	16°	18°	20°	22°	24°	26°	28°	30°	32°	34°	36°	38°	γ
4020	4011	3949	3841	3680	3469	3215	2930	2628	2320	2009	1698	1387	1088	816	578	381	222	113	52	cd
100%	100%	98%	96%	92%	86%	80%	73%	65%	58%	50%	42%	35%	27%	20%	14%	9%	6%	3%	1%	of 0°val

### Intensities in 90° c-plane

0°	2°	4°	6°	8°	10°	12°	14°	16°	18°	20°	22°	24°	26°	28°	30°	32°	34°	36°	38°	γ
4020	3996	3940	3837	3675	3460	3196	2909	2603	2293	1984	1680	1378	1090	826	597	396	231	118	54	cd
100%	99%	98%	95%	91%	86%	80%	72%	65%	57%	49%	42%	34%	27%	21%	15%	10%	6%	3%	1%	of 0°val

### Intensities in 180° c-plane

0°	2°	4°	6°	8°	10°	12°	14°	16°	18°	20°	22°	24°	26°	28°	30°	32°	34°	36°	38°	γ
4020	4011	3949	3841	3680	3469	3215	2930	2628	2320	2009	1698	1387	1088	816	578	381	222	113	52	cd
100%	100%	98%	96%	92%	86%	80%	73%	65%	58%	50%	42%	35%	27%	20%	14%	9%	6%	3%	1%	of 0°val

### Intensities in 270° c-plane

0°	2°	4°	6°	8°	10°	12°	14°	16°	18°	20°	22°	24°	26°	28°	30°	32°	34°	36°	38°	γ
4020	3996	3940	3837	3675	3460	3196	2909	2603	2293	1984	1680	1378	1090	826	597	396	231	118	54	cd
100%	99%	98%	95%	91%	86%	80%	72%	65%	57%	49%	42%	34%	27%	21%	15%	10%	6%	3%	1%	Of 0°val



### Colour Details

<b>Correlated Colour Temperature, Target</b>	CCT = 4000K
<b>Correlated Colour Temperature, Measured</b>	CCT = 3869K
<b>Colour Rendering Index</b>	CRI 90.7
<b>Colour Rendering Index R9 Value</b>	R9 = 54.4
<b>Colour Rendering TM30-18</b>	R <sub>f</sub> 88.7, R <sub>g</sub> 94.8
<b>Colour Quality Scale</b>	CQS = 90.6

<b>MacAdam Steps</b>	SDCM = 6.5
<b>Colour Coordinates CIE 1931</b>	(x;y) = (0.381;0.377)
<b>Colour Coordinates CIEs 1960</b>	(u;v) = (0.225; 0.334)
<b>Colour Deviation from BBL</b>	Duv = 0.0062
<b>Colour Coordinate CIEs 1976 (CIELUV)</b>	(u';v') = (0.225;0.225)

Colour Rendering Index per reference colour (CIE 1995)

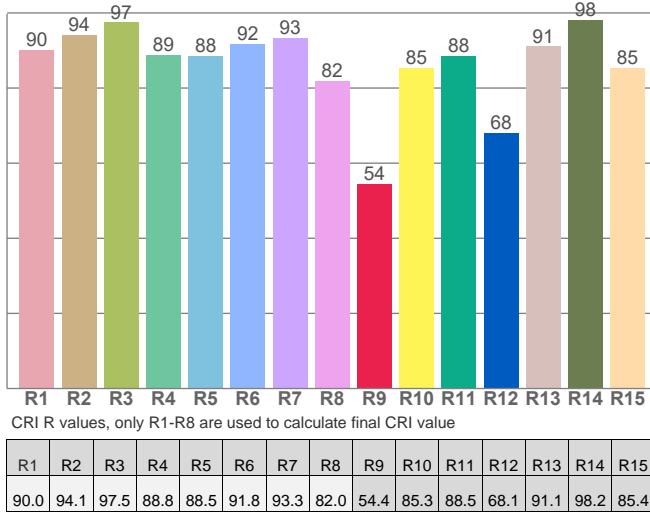

TM30-18 R<sub>f</sub>-values per hue bin

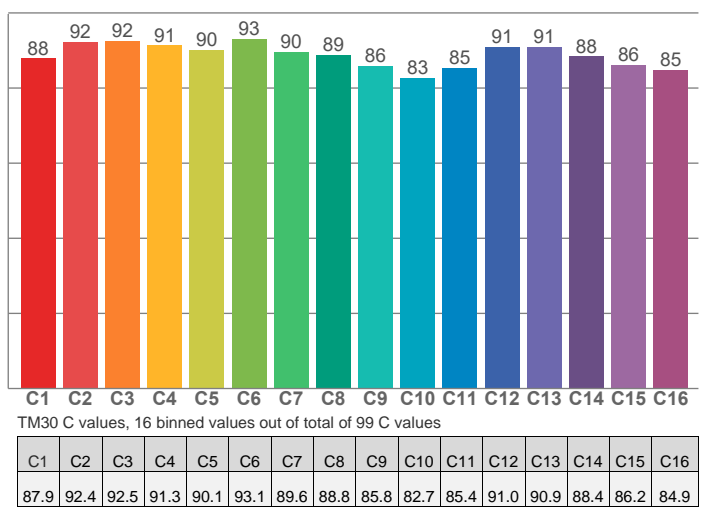

CIE 1931

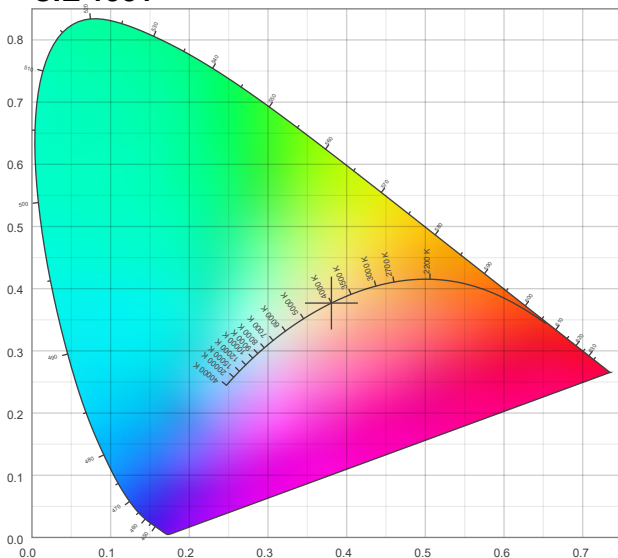

CIE 1931 – Zoomed

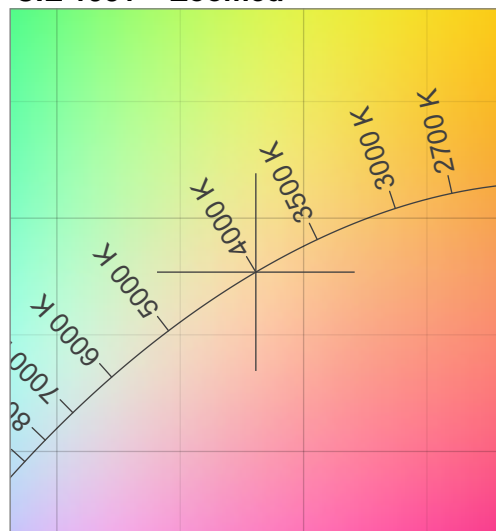

### Iso-intensity Diagram (Iso-Candela)

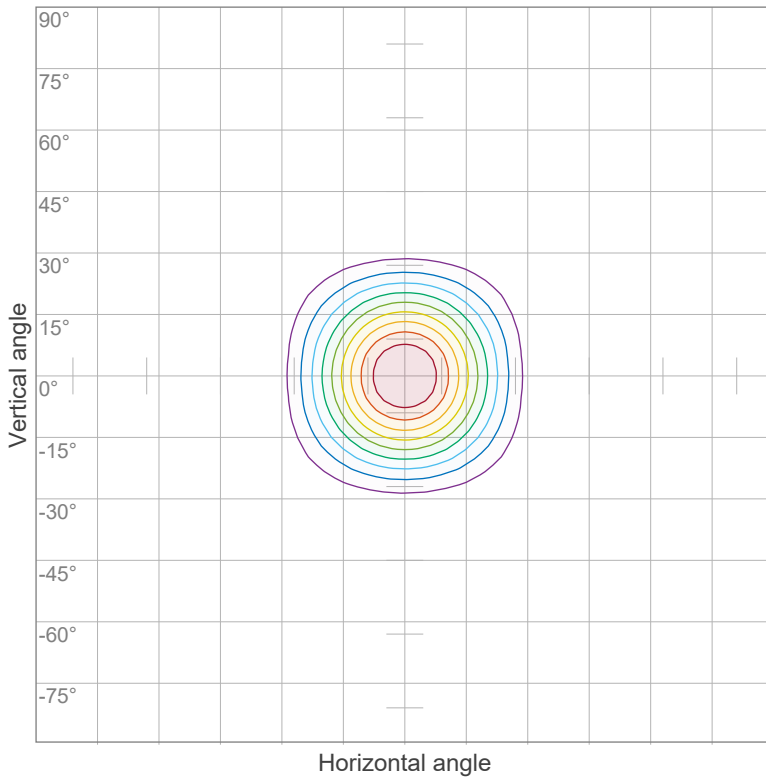

90 %	3623.1 cd
80 %	3220.6 cd
70 %	2818.0 cd
60 %	2415.4 cd
50 %	2012.9 cd
40 %	1610.3 cd
30 %	1207.7 cd
20 %	805.1 cd
10 %	402.6 cd

Peak intensity: 4025.7 cd  
Number of c-planes: 36

### Iso-illuminance Diagram (Iso-lux)

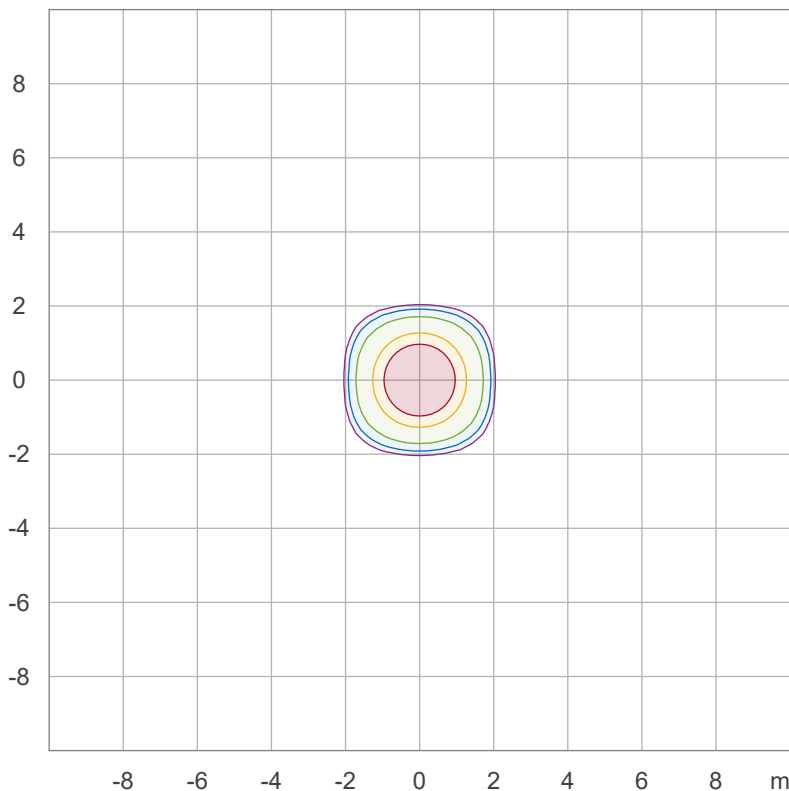

50.0 %	223.5 lx
30.0 %	134.1 lx
10.0 %	44.7 lx
5.0 %	22.4 lx
3.0 %	13.4 lx

Peak illuminance: 447.1 lx  
Mounting height: 3.0 m  
Number of c-planes: 36



### Light Planning – UGR table

Uncorrected, comprehensive UGR table according to 117-1995

Reflectances		70	70	50	50	30	70	70	50	50	30
ρ Ceiling		70	70	50	50	30	70	70	50	50	30
ρ Walls		50	30	50	30	30	50	30	50	30	30
ρ Floor		20	20	20	20	20	20	20	20	20	20
Room size		Viewed Crosswise					Viewed Endwise				
H = mounting height above eye level											
X	Y	(Viewing direction orthogonal to lamp length axis)					(Viewing direction parallel to lamp length axis)				
2H	2H	11.8	12.3	11.9	12.5	12.7	11.2	11.7	11.3	11.9	12.1
	3H	11.5	12.1	11.8	12.3	12.5	10.9	11.5	11.2	11.7	11.9
	4H	11.4	12.0	11.8	12.2	12.5	10.8	11.4	11.2	11.6	11.9
	6H	11.4	11.9	11.7	12.2	12.6	10.8	11.3	11.1	11.6	12.0
	8H	11.3	11.8	11.7	12.2	12.5	10.7	11.2	11.1	11.6	11.9
	12H	11.3	11.8	11.6	12.1	12.5	10.7	11.2	11.0	11.5	11.9
4H	2H	11.4	12.0	11.8	12.2	12.5	10.8	11.4	11.2	11.6	11.9
	3H	11.3	11.8	11.6	12.1	12.5	10.7	11.2	11.0	11.5	11.9
	4H	11.1	11.6	11.6	12.0	12.5	10.5	11.0	11.0	11.4	11.9
	6H	11.0	11.5	11.5	11.9	12.2	10.4	10.9	11.0	11.3	11.6
	8H	11.0	11.4	11.5	11.8	12.2	10.4	10.8	10.9	11.2	11.6
	12H	10.9	11.3	11.4	11.7	12.1	10.3	10.7	10.8	11.1	11.5
8H	4H	11.0	11.4	11.5	11.8	12.2	10.4	10.8	10.9	11.2	11.6
	6H	10.9	11.2	11.4	11.7	12.2	10.3	10.6	10.8	11.1	11.6
	8H	10.9	11.1	11.4	11.7	12.3	10.3	10.5	10.8	11.1	11.7
	12H	10.8	11.0	11.4	11.5	12.2	10.2	10.4	10.8	11.0	11.6
12H	4H	10.9	11.3	11.4	11.7	12.1	10.3	10.7	10.8	11.1	11.5
	6H	10.9	11.1	11.4	11.7	12.3	10.3	10.5	10.8	11.1	11.7
	8H	10.8	11.0	11.4	11.5	12.1	10.2	10.4	10.8	10.9	11.6

**Variations with the observer position for the luminaire spacings, S:**

S = 1.0H	6.1 / -20.4	6.0 / -22.3
S = 1.5H	8.9 / -20.6	8.8 / -22.5
S = 2.0H	10.9 / -20.9	10.8 / -23.0

### Coefficients of Utilization

Ceiling reflectance	80	70	50	30	10	0												
Wall reflectance	70 50 30	10 70 50	30 10 50	30 10 50	30 10 50	30 10 0												
Floor reflectance	20 20 20	20 20 20	20 20 20	20 20 20	20 20 20	20 20 0												
<b>RCR</b>	<b>(RCR: Room Cavity Ratio)</b>																	
	Room Values are expressed as percentage of Lumen delivered to the task surface																	
0	119	119	119	119	116	116	116	116	111	111	111	106	106	106	102	102	102	100
1	114	112	110	108	112	110	108	106	106	104	103	102	101	100	99	98	97	95
2	110	106	102	99	108	104	101	98	101	98	96	98	96	94	95	93	92	90
3	105	100	96	93	104	99	95	92	96	93	90	94	91	89	92	89	88	86
4	101	95	90	87	100	94	90	86	92	88	85	90	87	84	88	86	83	82
5	97	90	86	82	96	90	85	82	88	84	81	86	83	80	85	82	80	78
6	94	86	81	78	92	86	81	77	84	80	77	83	79	76	82	78	76	75
7	90	82	77	74	89	82	77	74	81	76	73	79	76	73	78	75	73	71
8	87	79	74	70	86	78	74	70	77	73	70	76	73	70	75	72	69	68
9	84	76	71	67	83	75	70	67	74	70	67	73	70	67	73	69	67	65
10	81	73	68	64	80	72	67	64	71	67	64	71	67	64	70	66	64	63



**Flicker Details**

<b>Flicker Meter Type</b>	Viso Systems LabFlicker
<b>Frequency of Input Power</b>	60 Hz
<b>Flicker/TLA Sample Rate</b>	20000 sample/s
<b>Measurement Time</b>	
<b>PstLM</b>	180 sec
<b>All other indices</b>	1.2 sec

<b>Flicker Indices (IES)</b>	
<b>Flicker Percentage</b>	39.04%
<b>Flicker Frequency</b>	120.48 Hz
<b>Flicker Index</b>	0.12
<b>Flicker SVM Value</b>	1.38
<b>Flicker PstLM Value</b>	0.03

**Flicker Frame**

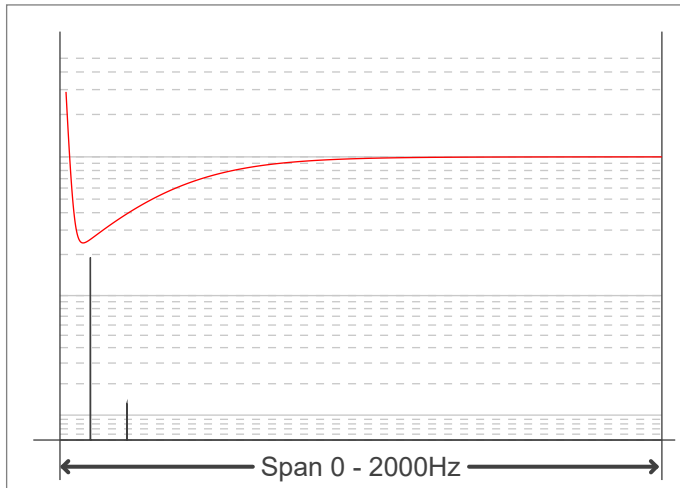

**Flicker FFT (flicker curve in frequency domain)**

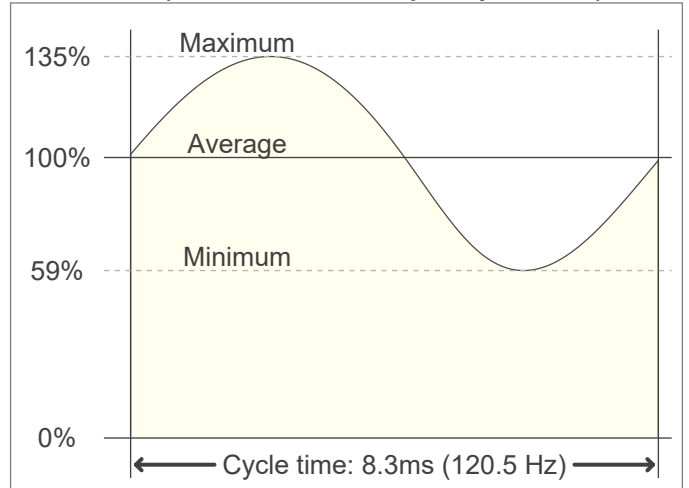

**IEEE 1789 Frequency/Modulation Plot**

