



TECHLUME

A U S T R A L I A

LM-79 Test Report

Testing Method:	IES Approved Method: Electrical and Photometric Measurements of Solid-State Lighting Products
Relevant Standards:	IES LM-79-08
Test Date and Time:	20/07/2023 9:07:12 AM
Test Location:	Techlume Australia - East Goderich Street Deloraine, TAS 7304
Operator:	Johnny Elmer
Measurement Number:	VFR-230720-0133-MS
Measurement Method:	Far Field, Type C Horizontal
Measurement Distance:	446.4 cm

Equipment Used

System Name:	LabSpion Goniometer
Sensor Name / Model:	Viso LabSensor Model2 / Freedom VIS (Custom Viso)
Spectrometer Range:	360 nm – 830 nm
Calibration Date:	7/12/2022
Flicker Meter Type:	Viso Systems LabFlicker
Manufacturer:	Viso Systems, Denmark

Test Conditions

Ambient Temperature:	25 °C ± 1 °C
----------------------	--------------

Remarks

The results stated in this report represent the tested sample only. All photometric and colourimetric data has been measured in compliance with IES LM-79-08 standards.



Product Overview

Product Description: AUSTIN 15W Square Bulkhead, IP65, Black, 2CCT 3000K/4000K

Item Number: LC3927 (4000K)

Manufacturer: Decrolux Lighting Pty Ltd

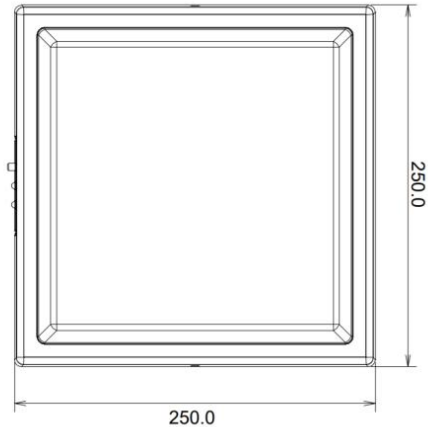

Photometric Measurements

Total Luminous Flux	Luminous Efficacy	Luminous Intensity
1770 lm	125 Lumen/watt	560 cd

Correlated Colour Temperature, Target	Correlated Colour Temperature, Measured	Colour Rendering Index (CRI)
4000 K	4018 K	Ra 84.1

Electrical Measurements

Input Voltage	Input Current	Input Power	Input Voltage Frequency
240 VAC	0.063 A	14.2 W	60 Hz

Power Factor	Stabilisation Time	Stabilisation Variation	Hours Operated Prior to Test
0.93	Lamp stabilized in 45 min 54 sec	-2.2%	0 hours



Spectral Power Distribution (SPD)

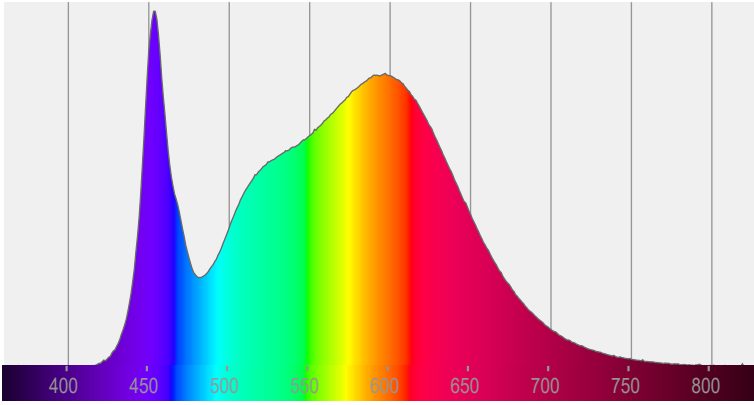

Input Power Curve

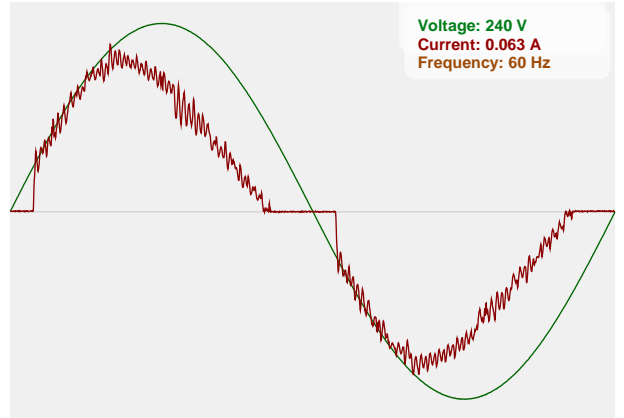

Flicker Details

Flicker Sample Rate	Flicker Percentage	Flicker Frequency	Flicker Index
20000 sample/s	0.47%	117.65 Hz	0

Flicker SVM Value	Flicker PstLM Value	Measurement Time (PstLM)	Measurement Time (all other indices)
0.01	0.14	180 s	1.2 s

IEEE 1789 Frequency/Modulation Plot

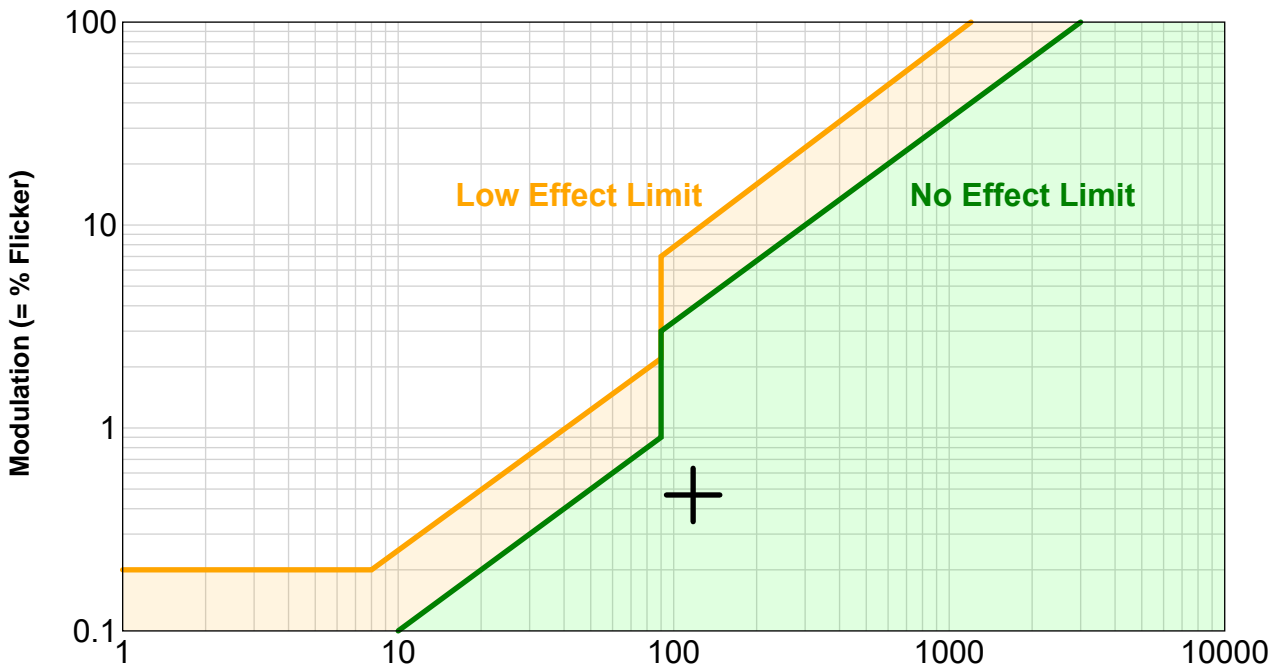

Angular Distribution – 0° / 90° Plane

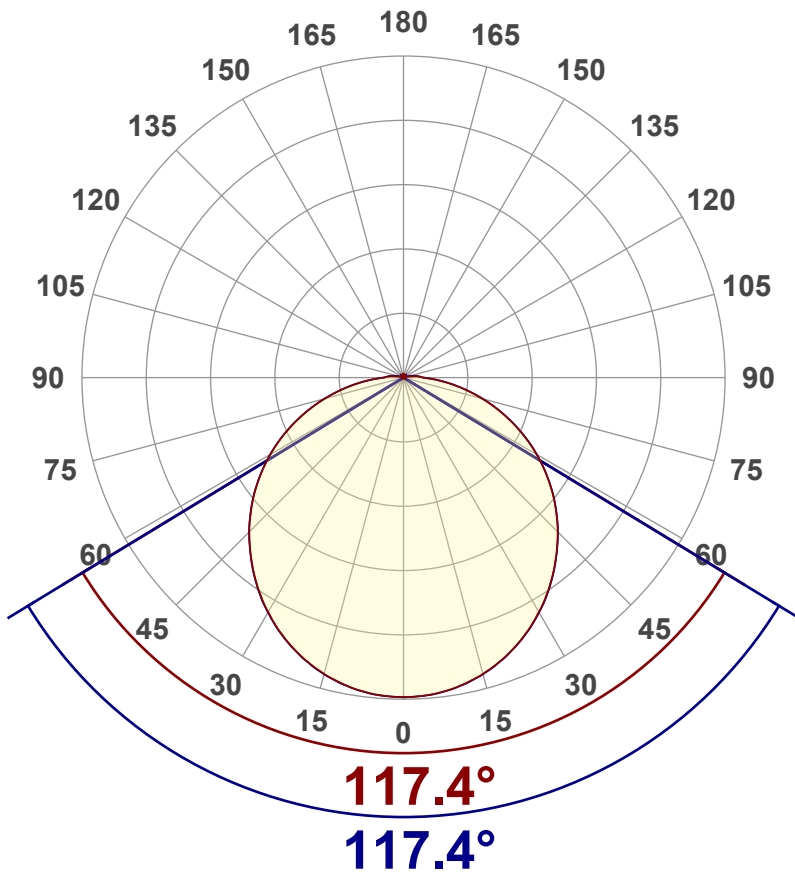

Main Values

Total Lumen Output	1770 lm
Lumen Up%	2.52%
Lumen Down%	97.48%
Peak Intensity	560 cd
Beam Angle (90%)	117.4°

Cut-off Angle

Average 2.5%	202.9°
--------------	--------

Field Angle

Average 10%	172.1°
-------------	--------

Intensity Ratio

In 120° Cone	72.7%
In 90° Cone	48.8%

C000-C180

C090-C270

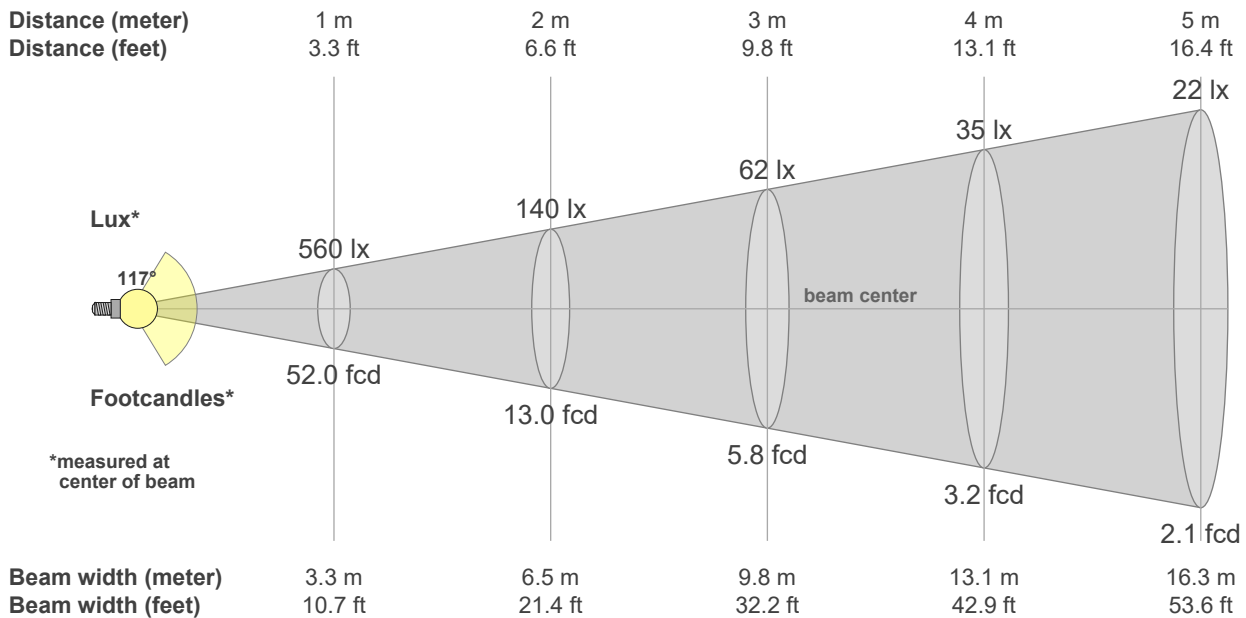

Beam intensities from 1 – 20m

1	2	3	4	5	6	7	8	9	10	11	12	13	14	15	16	17	18	19	20	m	
3.3	6.6	9.8	13.1	16.4	19.7	23	26.2	29.5	32.8	36.1	39.4	42.7	45.9	49.2	52.5	55.8	59.1	62.3	65.6	ft	
560	140	62	35	22	16	11	9	7	6	5	4	3	3	2	2	2	2	2	1	lux	
52	13	5.8	3.2	2.1	1.4	1.1	0.8	0.6	0.5	0.4	0.4	0.3	0.3	0.2	0.2	0.2	0.2	0.2	0.1	0.1	fc



Colour Details

Colour Rendering Index (CRI)	Colour Rendering Index R9 Value	Colour Rendering TM30-18
Ra 84.1	R9 = 12.8	R _f 84.0, R _g 94.1

Colour Quality Scale	Correlated Colour Temperature, Target	Correlated Colour Temperature, Measured
CQS = 83.0	CCT = 4000 K	CCT = 4018 K

MacAdam Steps	Colour Coordinates CIE 1931	Colour Deviation from BBL
SDCM = 1.0	(x;y) = (0.381;0.377)	Duv = 0.0012

Colour Rendering Index per reference colour (CIE 1995)

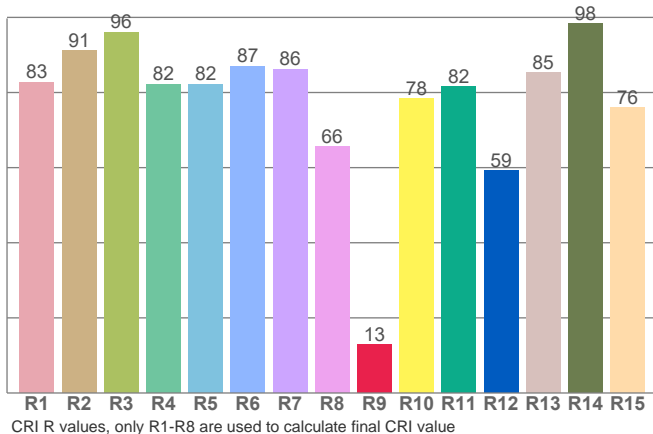

R1	R2	R3	R4	R5	R6	R7	R8	R9	R10	R11	R12	R13	R14	R15
82.8	91.1	96.0	82.2	82.2	87.0	86.2	65.6	12.8	78.3	81.6	59.1	85.2	98.3	75.9

TM30-18 Rf-values per hue bin

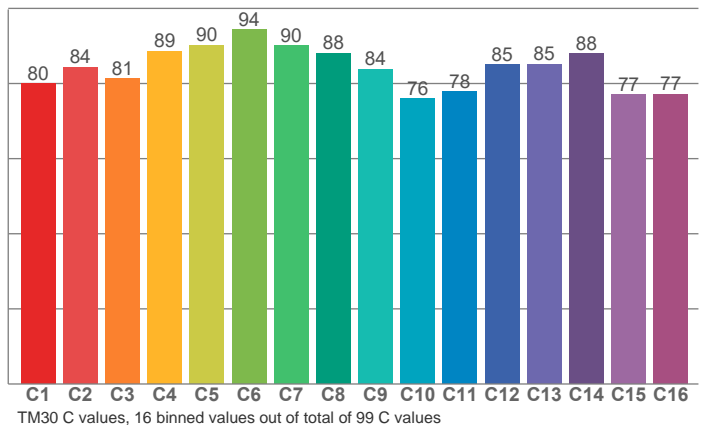

C1	C2	C3	C4	C5	C6	C7	C8	C9	C10	C11	C12	C13	C14	C15	C16
80.0	84.4	81.3	88.6	90.2	94.3	90.0	88.0	83.8	75.9	77.9	85.0	85.2	87.9	77.1	77.2

CIE 1931

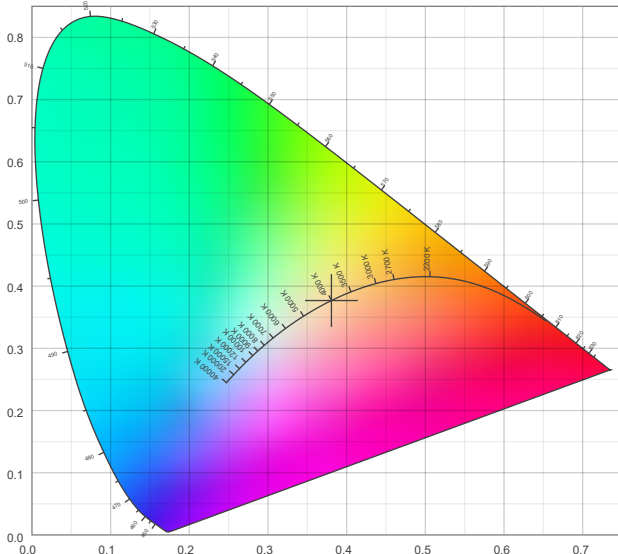

CIE 1931 – Zoomed

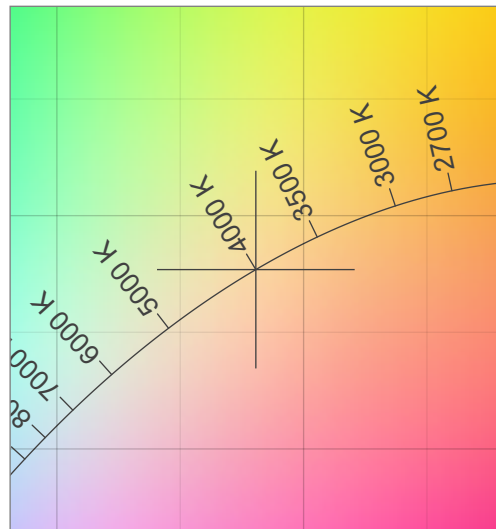

Iso-intensity Diagram (Iso-Candela)

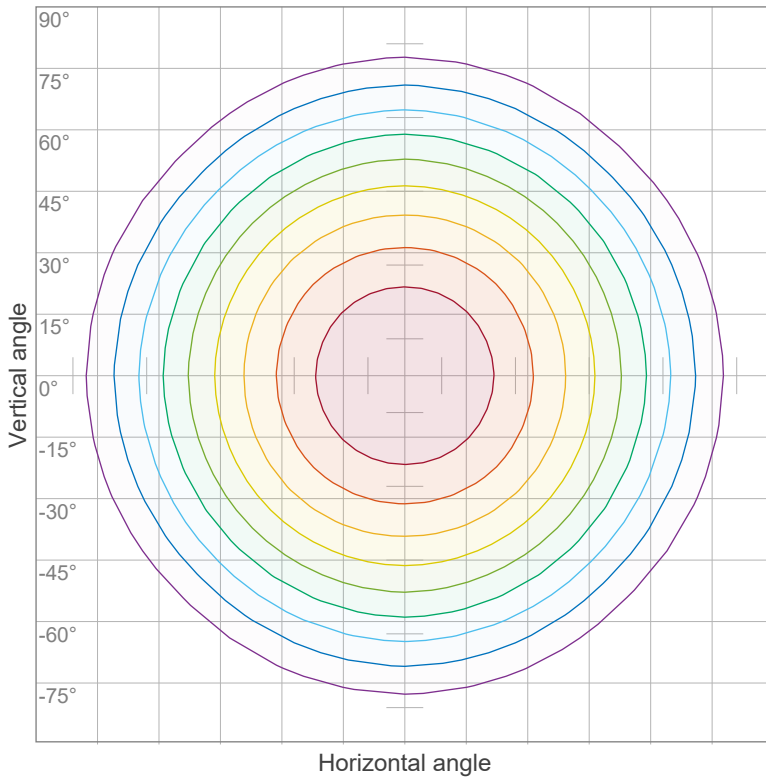

90 %	503.9 cd
80 %	447.9 cd
70 %	391.9 cd
60 %	335.9 cd
50 %	279.9 cd
40 %	223.9 cd
30 %	168.0 cd
20 %	112.0 cd
10 %	56.0 cd

Peak intensity: 559.9 cd
Number of c-planes: 16

Iso-illuminance Diagram (Iso-lux)

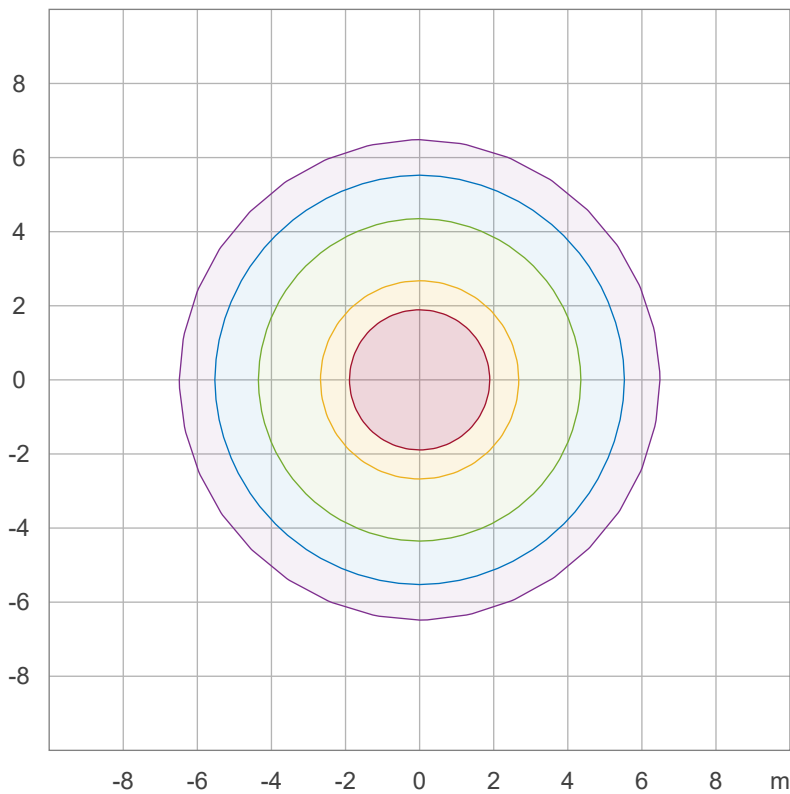

50.0 %	31.1 lx
30.0 %	18.7 lx
10.0 %	6.2 lx
5.0 %	3.1 lx
3.0 %	1.9 lx

Peak illuminance: 62.2 lx
Mounting height: 3.0 m
Number of c-planes: 16



Light Planning – UGR table

Uncorrected, comprehensive UGR table according to 117-1995

Reflectances		70	70	50	50	30	70	70	50	50	30
ρ Ceiling		70	70	50	50	30	70	70	50	50	30
ρ Walls		50	30	50	30	30	50	30	50	30	30
ρ Floor		20	20	20	20	20	20	20	20	20	20
Room size		Viewed Crosswise					Viewed Endwise				
H = mounting height above eye level		(Viewing direction orthogonal to lamp length axis)					(Viewing direction parallel to lamp length axis)				
X	Y										
2H	2H	20.6	21.8	20.9	22.2	22.5	20.6	21.8	20.9	22.2	22.5
	3H	22.2	23.5	22.7	23.8	24.1	22.2	23.5	22.7	23.8	24.1
	4H	23.0	24.2	23.4	24.5	24.8	23.0	24.2	23.4	24.5	24.8
	6H	23.7	24.8	24.0	25.1	25.5	23.7	24.8	24.0	25.1	25.5
	8H	23.9	25.0	24.3	25.3	25.8	23.9	25.0	24.3	25.3	25.8
	12H	24.1	25.2	24.5	25.5	26.0	24.1	25.2	24.5	25.5	26.0
4H	2H	21.2	22.4	21.6	22.8	23.1	21.2	22.4	21.6	22.8	23.1
	3H	23.1	24.2	23.5	24.5	25.0	23.1	24.2	23.5	24.5	25.0
	4H	23.9	24.9	24.4	25.3	25.9	23.9	24.9	24.4	25.3	25.9
	6H	24.7	25.6	25.2	26.0	26.4	24.7	25.6	25.2	26.0	26.4
	8H	25.0	25.8	25.6	26.3	26.7	25.0	25.8	25.6	26.3	26.7
	12H	25.3	26.0	25.8	26.4	27.0	25.3	26.0	25.8	26.5	27.0
8H	4H	24.2	25.1	24.8	25.5	25.9	24.2	25.1	24.8	25.5	25.9
	6H	25.2	25.8	25.7	26.3	26.9	25.2	25.8	25.7	26.3	26.9
	8H	25.6	26.2	26.2	26.7	27.4	25.6	26.2	26.2	26.7	27.4
	12H	26.0	26.5	26.6	27.0	27.7	26.0	26.5	26.6	27.0	27.7
12H	4H	24.3	25.0	24.8	25.4	25.9	24.3	25.0	24.8	25.4	25.9
	6H	25.3	25.8	25.8	26.4	27.1	25.3	25.8	25.8	26.4	27.1
	8H	25.7	26.2	26.3	26.8	27.4	25.7	26.2	26.3	26.8	27.4
Variations with the observer position for the luminaire spacings, S:											
S = 1.0H		0.1 / -0.1					0.1 / -0.1				
S = 1.5H		0.1 / -0.1					0.1 / -0.1				
S = 2.0H		0.3 / -0.4					0.3 / -0.4				

Coefficients of Utilization

	80			70			50			30			10			0		
Ceiling reflectance	70	50	30	10	70	50	30	10	50	30	10	50	30	10	50	30	10	0
Wall reflectance	20	20	20	20	20	20	20	20	20	20	20	20	20	20	20	20	20	0
Floor reflectance																		
RCR		(RCR: Room Cavity Ratio)																
Room Values are expressed as percentage of Lumen delivered to the task surface																		
0	118	118	118	118	115	115	115	115	110	110	110	105	105	105	100	100	100	97
1	107	102	97	93	104	99	95	91	94	91	88	90	87	84	86	84	82	79
2	97	88	81	75	94	86	79	73	82	76	71	78	73	69	75	71	67	65
3	88	77	68	61	85	75	67	61	72	65	59	69	63	58	66	61	57	54
4	80	68	59	52	78	66	58	51	63	56	50	61	54	49	58	53	48	46
5	74	60	51	44	71	59	50	44	57	49	43	54	48	42	52	46	42	40
6	68	54	45	39	66	53	45	38	51	43	38	49	42	37	47	41	37	34
7	63	49	40	34	61	48	40	34	46	39	33	45	38	33	43	37	32	30
8	59	45	36	30	57	44	36	30	42	35	30	41	34	29	40	34	29	27
9	55	41	33	27	53	40	32	27	39	32	27	38	31	26	37	31	26	24
10	51	38	30	24	50	37	30	24	36	29	24	35	28	24	34	28	24	22

