



TECHLUME

A U S T R A L I A

LM-79 Test Report

Testing Method:	IES Approved Method: Electrical and Photometric Measurements of Solid-State Lighting Products
Relevant Standards:	IES LM-79-08
Test Date and Time:	4/04/2023 11:33:51 AM
Test Location:	Techlume Australia - East Goderich Street Deloraine, TAS 7304
Operator:	Johnny Elmer
Measurement Number:	VFR-230404-0043-MS
Measurement Method:	Far Field, Type C Horizontal
Measurement Distance:	457.7 cm

Equipment Used

System Name:	LabSpion Goniometer
Sensor Name / Model:	Viso LabSensor Model2 / Freedom VIS (Custom Viso)
Spectrometer Range:	360 nm – 830 nm
Calibration Date:	7/12/2022
Flicker Meter Type:	Viso Systems LabFlicker
Manufacturer:	Viso Systems, Denmark

Test Conditions

Ambient Temperature:	25 °C ± 1 °C
----------------------	--------------

Remarks

The results stated in this report represent the tested sample only. All photometric and colourimetric data has been measured in compliance with IES LM-79-08 standards.



Product Overview

Product Description: KINGSTON 25W Street Light, Spigot Dia 60mm, IP65, 4000K, T3 optic

Item Number: LC6105-T3

Manufacturer: Decrolux Lighting Pty Ltd

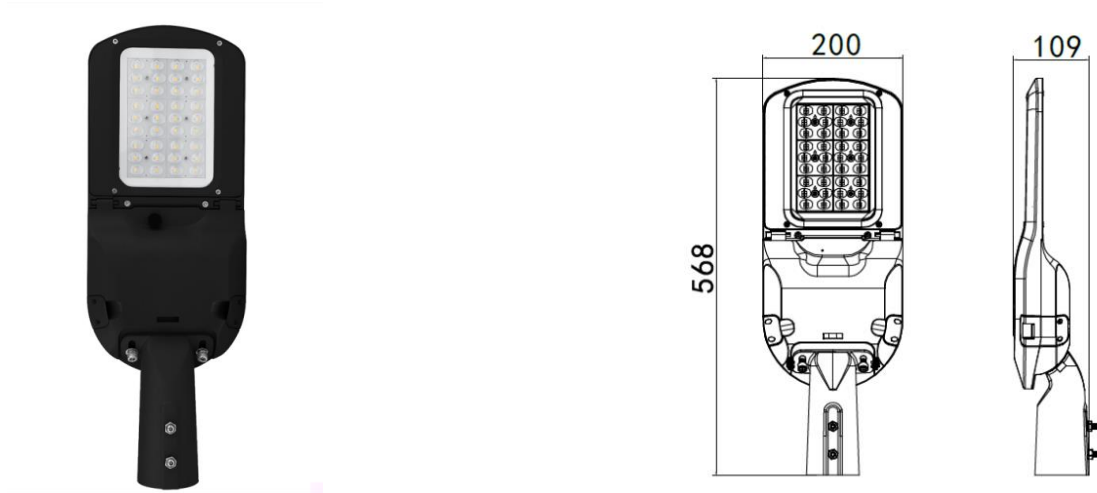

Photometric Measurements

Total Luminous Flux	Luminous Efficacy	Luminous Intensity
4063 lm	161 Lumen/watt	2316 cd

Correlated Colour Temperature, Target	Correlated Colour Temperature, Measured	Colour Rendering Index (CRI)
4000 K	3919 K	Ra 80.1

Electrical Measurements

Input Voltage	Input Current	Input Power	Input Voltage Frequency
240 VAC	0.109 A	25.3 W	60 Hz

Power Factor	Stabilisation Time	Stabilisation Variation	Hours Operated Prior to Test
0.96	Lamp stabilized in 36 min 3 sec	-0.7%	0 hours

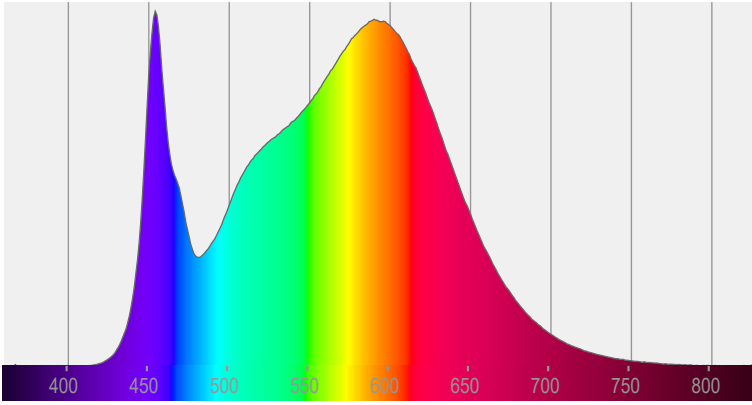
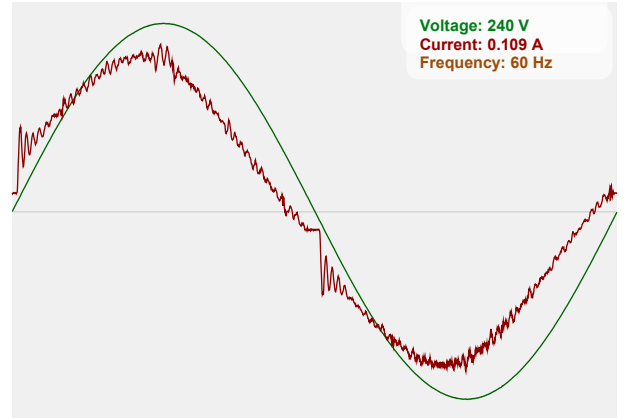

Spectral Power Distribution (SPD)

Input Power Curve

Flicker Details

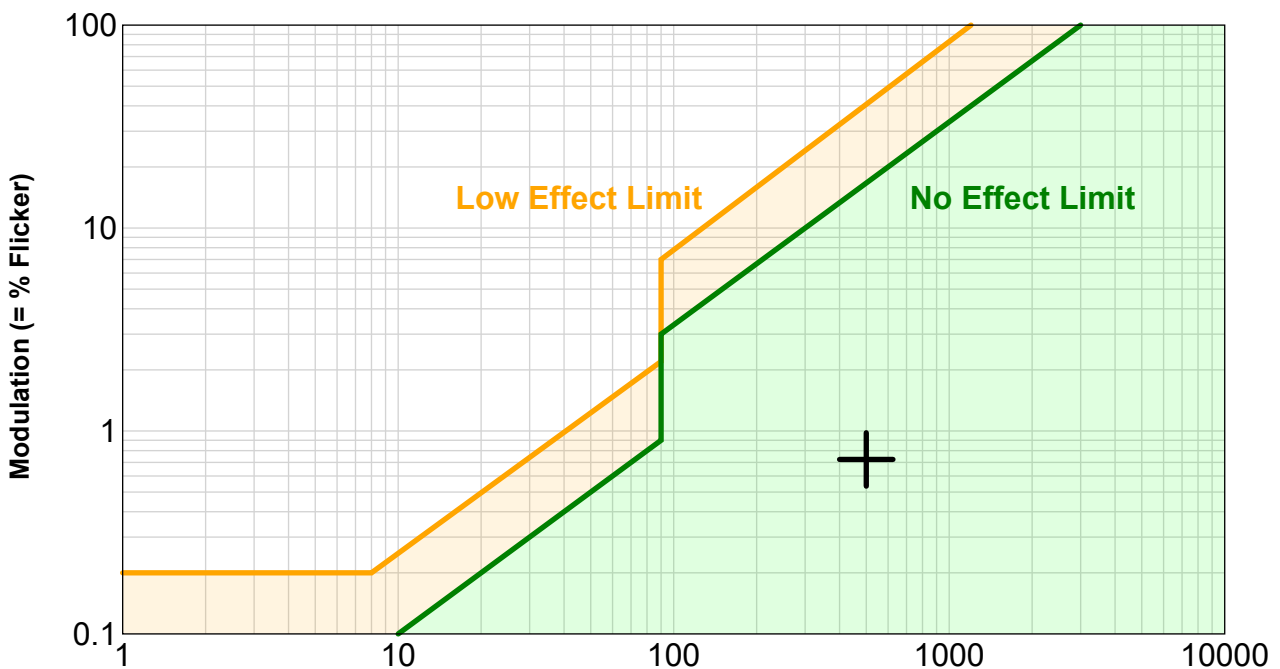
Flicker Sample Rate	Flicker Percentage	Flicker Frequency	Flicker Index
20000 sample/s	0.72%	500 Hz	0

Flicker SVM Value	Flicker PstLM Value	Measurement Time (PstLM)	Measurement Time (all other indices)
0.01	0.03	180 s	1.2 s

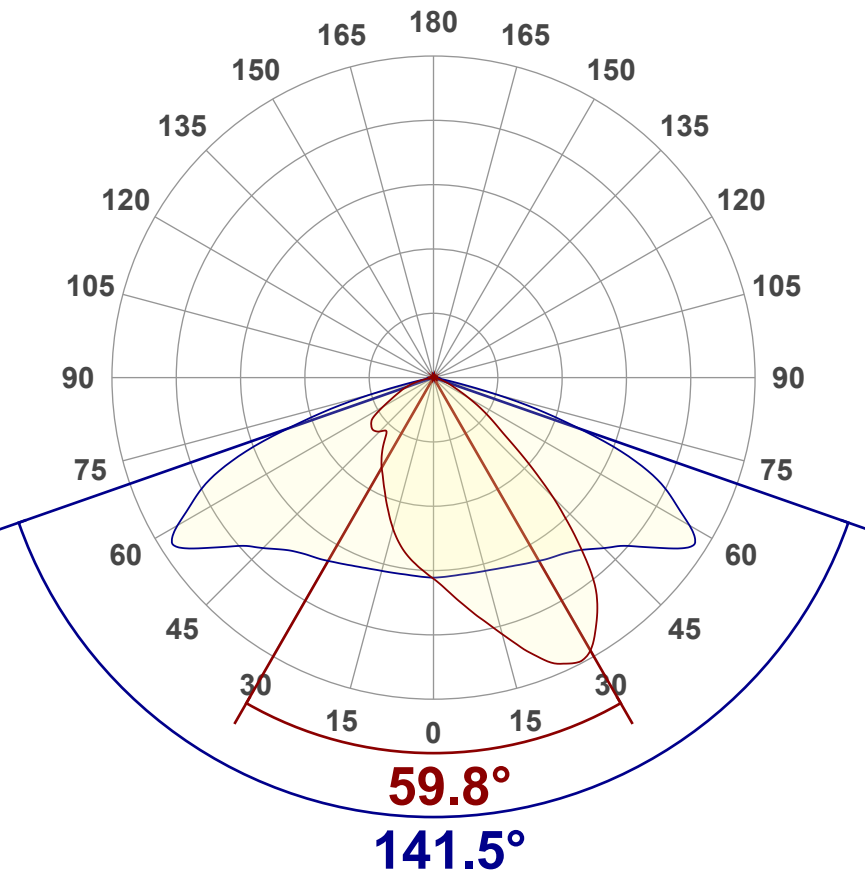
IEEE 1789 Frequency/Modulation Plot

Angular Distribution – 0° / 90° Plane



Main Values

Total Lumen Output	4063 lm
Lumen Up%	0.28%
Lumen Down%	99.72%
Peak Intensity	2316 cd
Beam Angle (90%)	141.5°

Cut-off Angle

Average 2.5%	157.9°
--------------	--------

Field Angle

Average 10%	144.4°
-------------	--------

Intensity Ratio

In 120° Cone	78.9%
In 90° Cone	49.1%

C000-C180

C090-C270

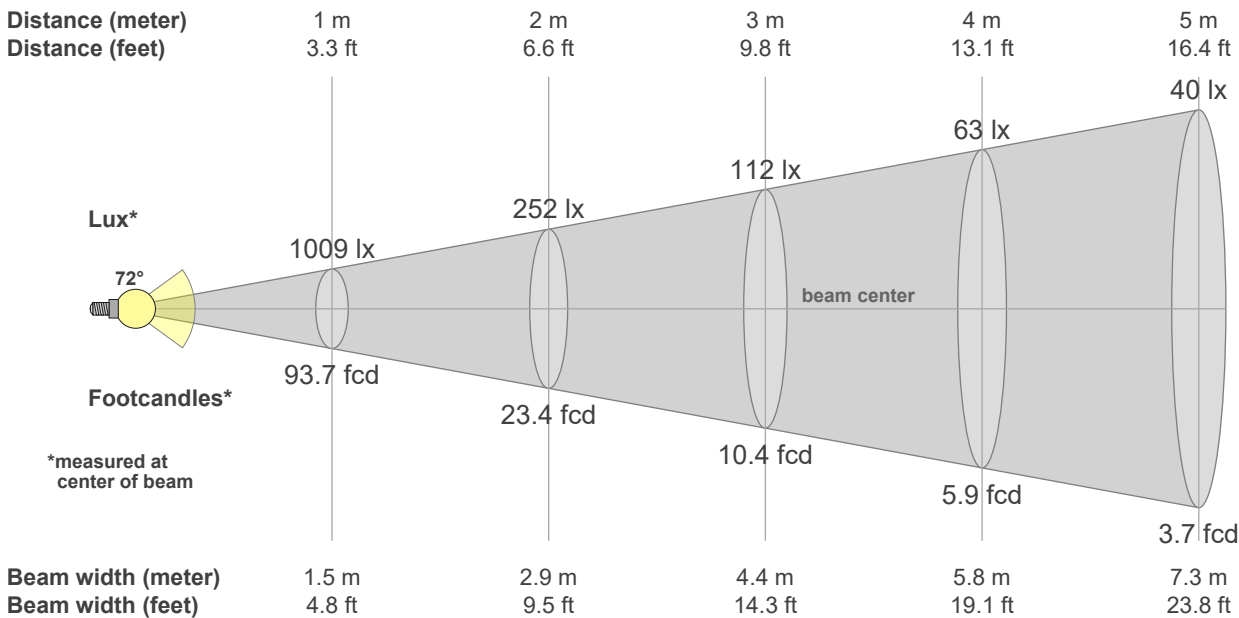

Beam intensities from 1 – 20m

1	2	3	4	5	6	7	8	9	10	11	12	13	14	15	16	17	18	19	20	m
3.3	6.6	9.8	13.1	16.4	19.7	23	26.2	29.5	32.8	36.1	39.4	42.7	45.9	49.2	52.5	55.8	59.1	62.3	65.6	ft
1009	252	112	63	40	28	21	16	12	10	8	7	6	5	4	4	3	3	3	3	lux
93.7	23.4	10.4	5.9	3.7	2.6	1.9	1.5	1.2	0.9	0.8	0.7	0.6	0.5	0.4	0.4	0.3	0.3	0.3	0.2	fc



Colour Details

Colour Rendering Index (CRI)	Colour Rendering Index R9 Value	Colour Rendering TM30-18
Ra 80.1	R9 = -10.3	R _f 81.5, R _g 90.7

Colour Quality Scale	Correlated Colour Temperature, Target	Correlated Colour Temperature, Measured
CQS = 80.3	CCT = 4000 K	CCT = 3919 K

MacAdam Steps	Colour Coordinates CIE 1931	Colour Deviation from BBL
SDCM = 5.0	(x;y) = (0.381;0.377)	Duv = 0.0052

Colour Rendering Index per reference colour (CIE 1995)

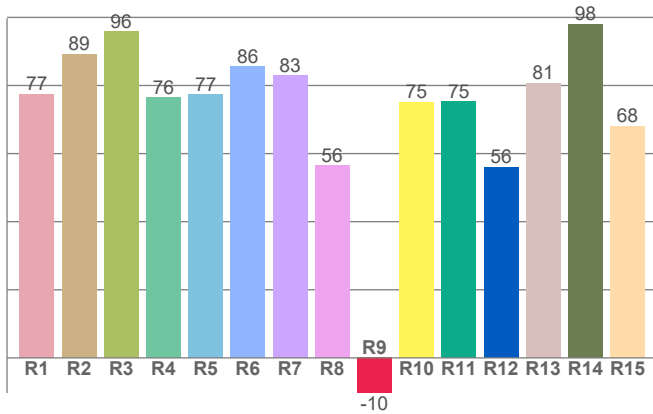

CRI R values, only R1-R8 are used to calculate final CRI value

R1	R2	R3	R4	R5	R6	R7	R8	R9	R10	R11	R12	R13	R14	R15
77.5	89.2	95.8	76.5	77.3	85.5	82.9	56.4	-10.3	75.1	75.3	56.0	80.7	98.0	68.1

TM30-18 Rf-values per hue bin

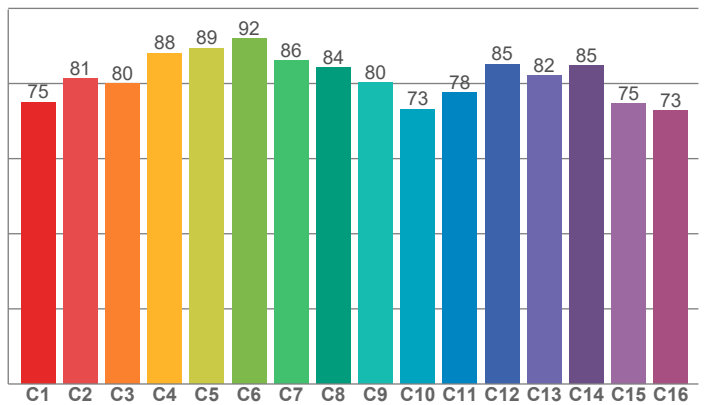

TM30 C values, 16 binned values out of total of 99 C values

C1	C2	C3	C4	C5	C6	C7	C8	C9	C10	C11	C12	C13	C14	C15	C16
75.1	81.2	80.0	88.1	89.4	91.9	86.0	84.2	80.3	73.2	77.5	85.2	82.1	84.7	74.7	72.8

CIE 1931

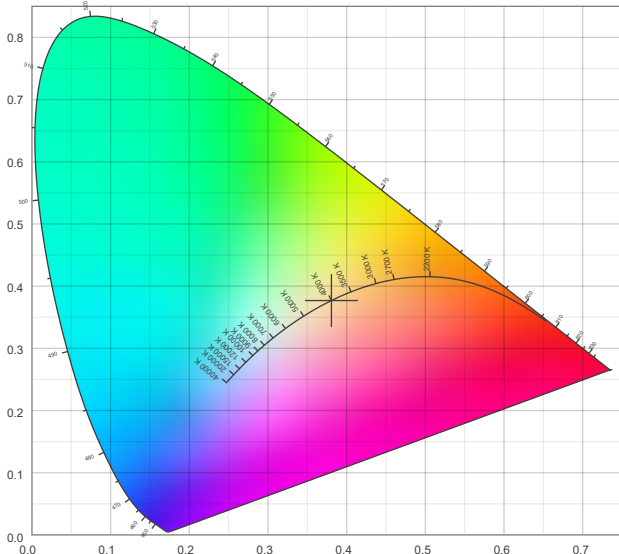

CIE 1931 – Zoomed

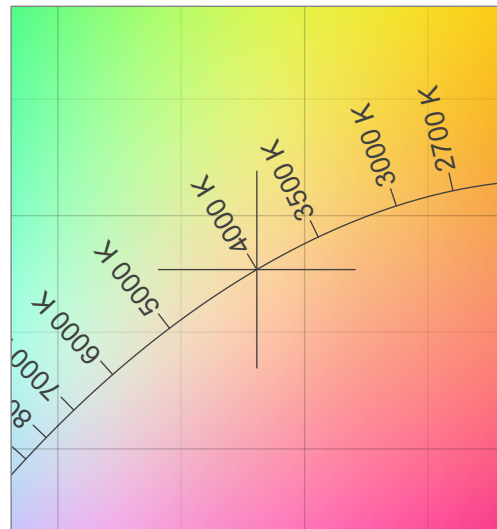

Iso-intensity Diagram (Iso-Candela)

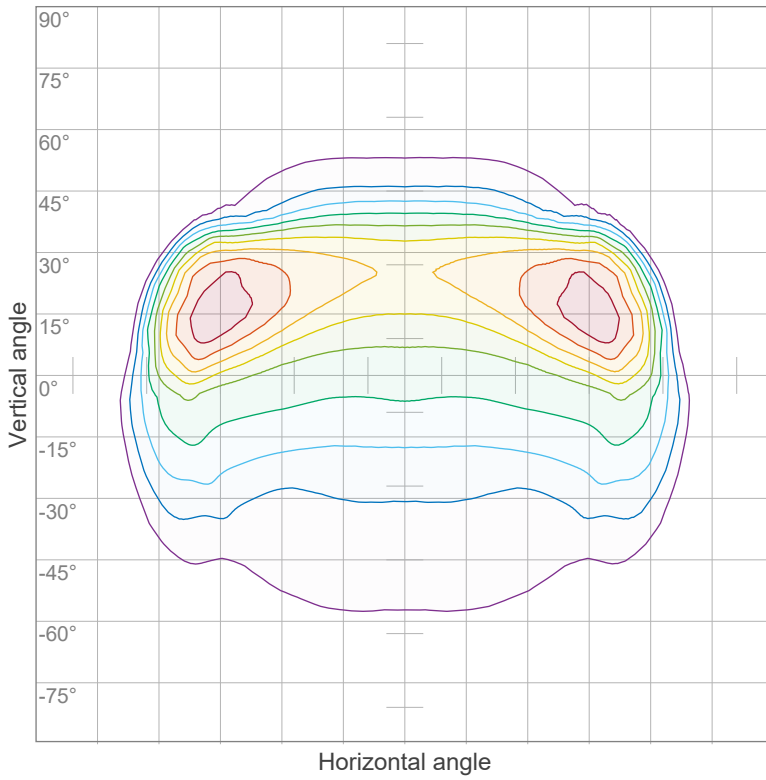

90 %	2083.4 cd
80 %	1851.9 cd
70 %	1620.4 cd
60 %	1388.9 cd
50 %	1157.5 cd
40 %	926.0 cd
30 %	694.5 cd
20 %	463.0 cd
10 %	231.5 cd

Peak intensity: 2314.9 cd
Number of c-planes: 72

Iso-illuminance Diagram (Iso-lux)

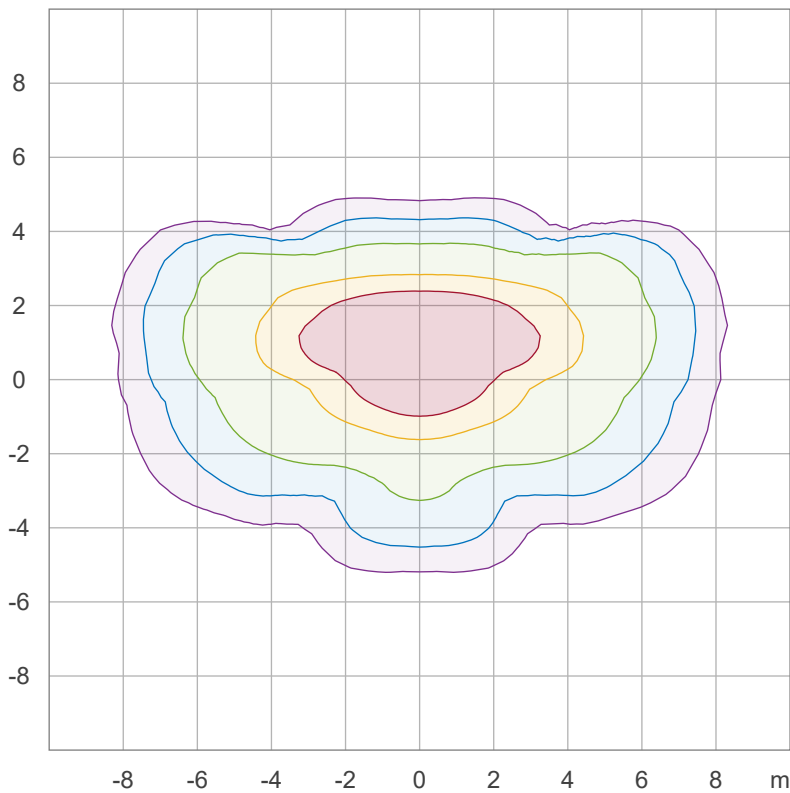

50.0 %	68.7 lx
30.0 %	41.2 lx
10.0 %	13.7 lx
5.0 %	6.9 lx
3.0 %	4.1 lx

Peak illuminance: 137.4 lx
Mounting height: 3.0 m
Number of c-planes: 72



Coefficients of Utilization

Ceiling reflectance	80			70			50			30			10			0		
Wall reflectance	70	50	30	10	70	50	30	10	50	30	10	50	30	10	50	30	10	0
Floor reflectance	20	20	20	20	20	20	20	20	20	20	20	20	20	20	20	20	20	0
RCR	(RCR: Room Cavity Ratio)																	
	Room Values are expressed as percentage of Lumen delivered to the task surface																	
0	119	119	119	119	116	116	116	116	111	111	106	106	106	102	102	102	100	100
1	109	104	100	96	106	102	98	95	98	95	92	94	91	89	90	88	86	84
2	99	90	83	78	96	88	82	77	85	79	75	81	77	73	78	75	71	69
3	89	79	70	64	87	77	69	63	74	67	62	71	65	61	68	64	60	57
4	81	69	60	53	79	68	59	53	65	58	52	63	56	51	60	55	50	48
5	74	61	52	45	72	60	51	45	58	50	44	56	49	43	54	48	43	41
6	68	54	45	38	66	53	45	38	52	44	38	50	43	37	48	42	37	35
7	63	49	40	33	61	48	39	33	46	39	33	45	38	33	44	37	32	30
8	58	44	35	29	57	44	35	29	42	35	29	41	34	29	40	33	29	27
9	54	40	32	26	53	40	32	26	39	31	26	37	31	26	36	30	26	24
10	51	37	29	23	49	36	29	23	35	28	23	34	28	23	34	27	23	21

