



TECHLUME

A U S T R A L I A

LM-79 Test Report

Testing Method:	IES Approved Method: Electrical and Photometric Measurements of Solid-State Lighting Products
Relevant Standards:	IES LM-79-08
Test Date and Time:	31/01/2024 2:43:33 PM
Test Location:	Techlume Australia - East Goderich Street Deloraine, TAS 7304
Operator:	Johnny Elmer
Measurement Number:	VFR-240131-0288-MS
Measurement Method:	Far Field, Type C Horizontal
Measurement Distance:	454.0 cm

Equipment Used

System Name:	LabSpion Goniometer
Sensor Name / Model:	Viso LabSensor Model2 / Freedom VIS (Custom Viso)
Spectrometer Range:	360 nm – 830 nm
Calibration Date:	16/12/2023
Flicker Meter Type:	Viso Systems LabFlicker
Manufacturer:	Viso Systems, Denmark

Test Conditions

Ambient Temperature:	25 °C ± 1 °C
----------------------	--------------

Remarks

The results stated in this report represent the tested sample only. All photometric and colourimetric data has been measured in compliance with IES LM-79-08 standards.



Product Overview

Product Description: KINGSTON 50W Street Light, Spigot Dia 60mm, IP65, 4000K, T2 Optic

Item Number: LC6115-T2

Manufacturer: Decrolux Lighting Pty Ltd

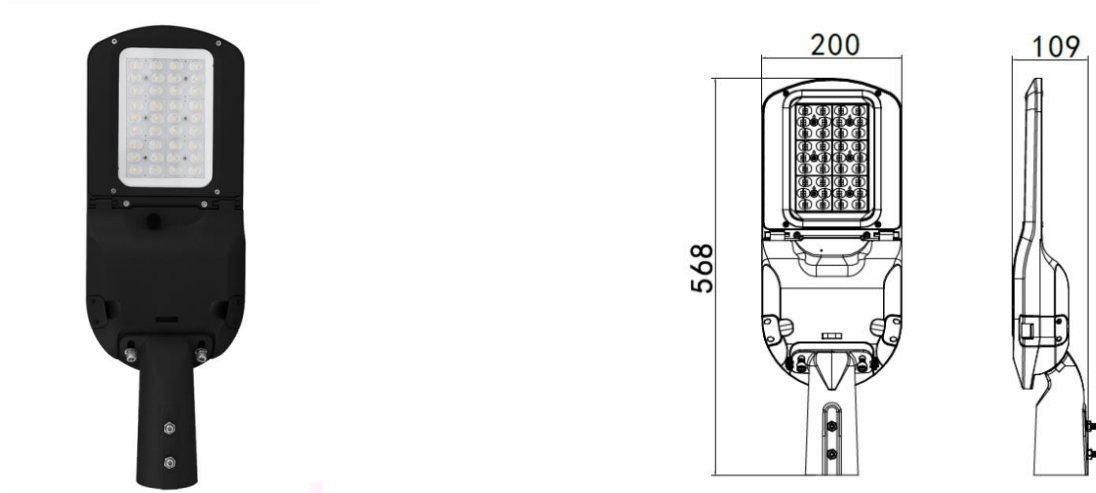

Photometric Measurements

Total Luminous Flux	Luminous Efficacy	Luminous Intensity
7926 lm	151 Lumen/watt	4562 cd

Correlated Colour Temperature, Target	Correlated Colour Temperature, Measured	Colour Rendering Index (CRI)
4000 K	3985 K	Ra 81.2

Electrical Measurements

Input Voltage	Input Current	Input Power	Input Voltage Frequency
240 VAC	0.224 A	52.6 W	60 Hz

Power Factor	Stabilisation Time	Stabilisation Variation	Hours Operated Prior to Test
0.98	Not completed	-0.9%	0 hours



Spectral Power Distribution (SPD)

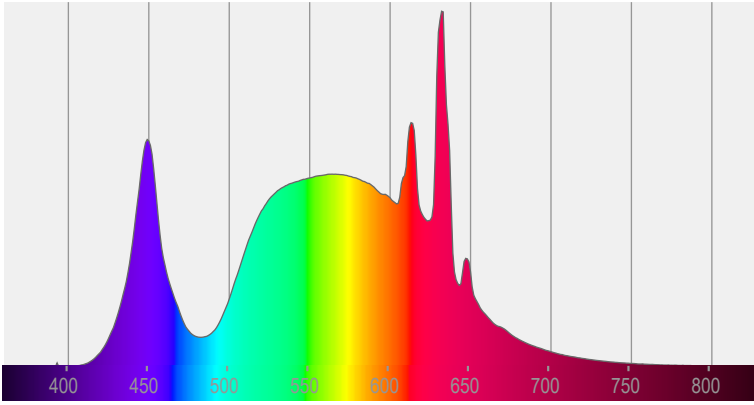

Input Power Curve

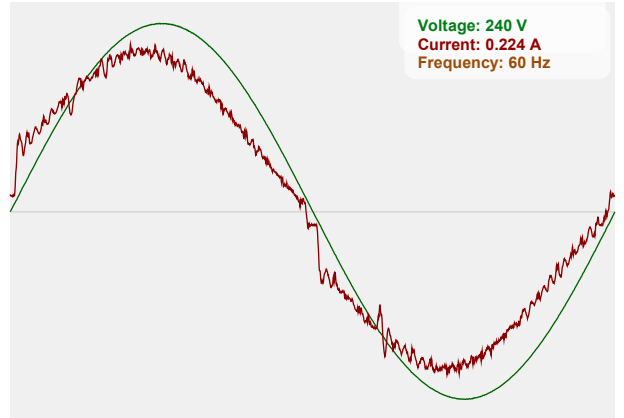

Flicker Details

Flicker Sample Rate	Flicker Percentage	Flicker Frequency	Flicker Index
20000 sample/s	0.52%	465.12 Hz	0

Flicker SVM Value	Flicker PstLM Value	Measurement Time (PstLM)	Measurement Time (all other indices)
0.01	0.03	180 s	1.2 s

IEEE 1789 Frequency/Modulation Plot

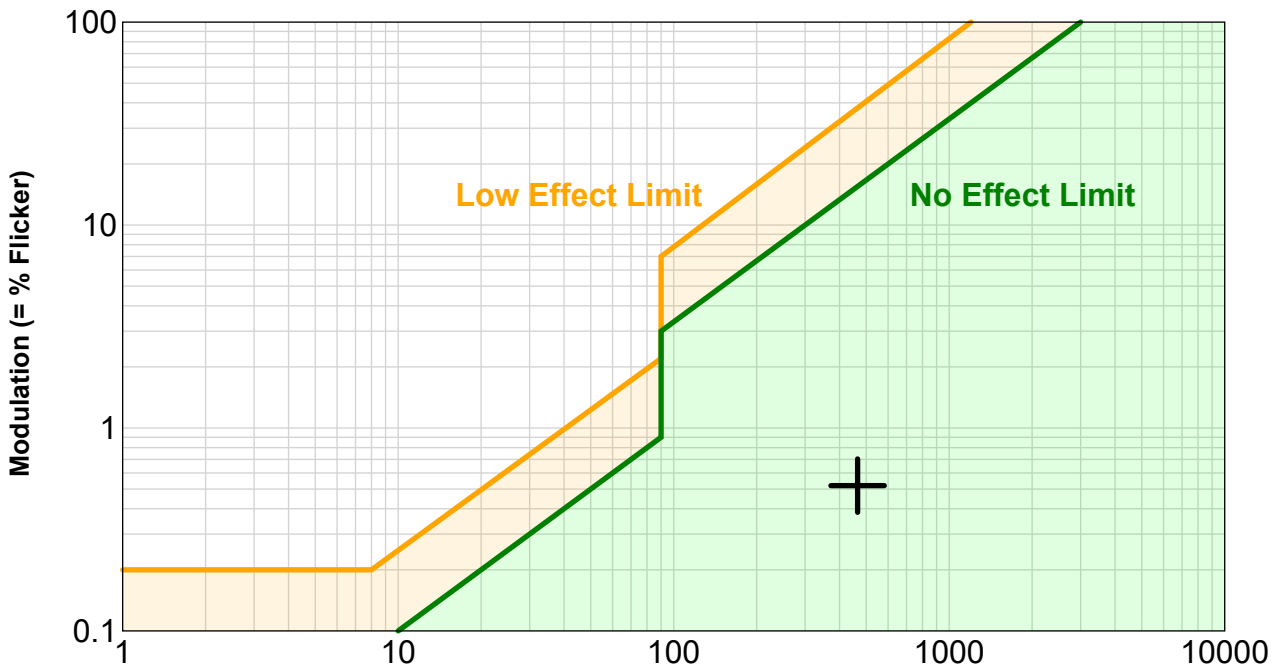

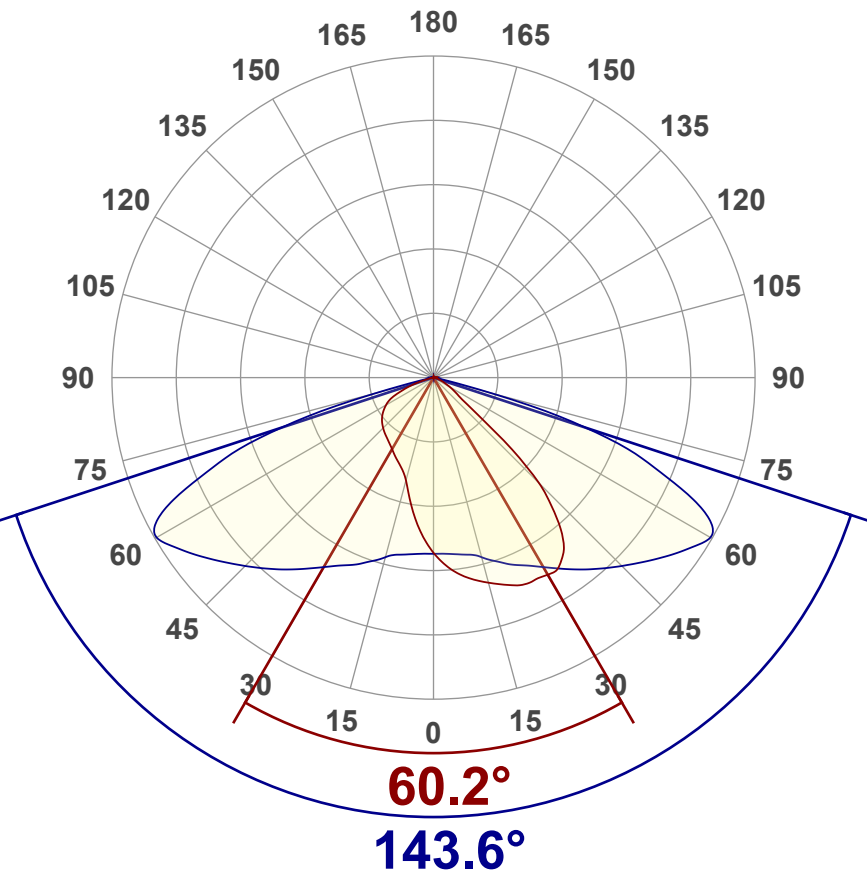
Angular Distribution – 0° / 90° Plane

Main Values

Total Lumen Output	7926 lm
Lumen Up%	0.22%
Lumen Down%	99.78%
Peak Intensity	4562 cd
Beam Angle (90%)	143.6°

Cut-off Angle

Average 2.5%	154.7°
---------------------	--------

Field Angle

Average 10%	140.6°
--------------------	--------

Intensity Ratio

In 120° Cone	78.4%
In 90° Cone	47.3%

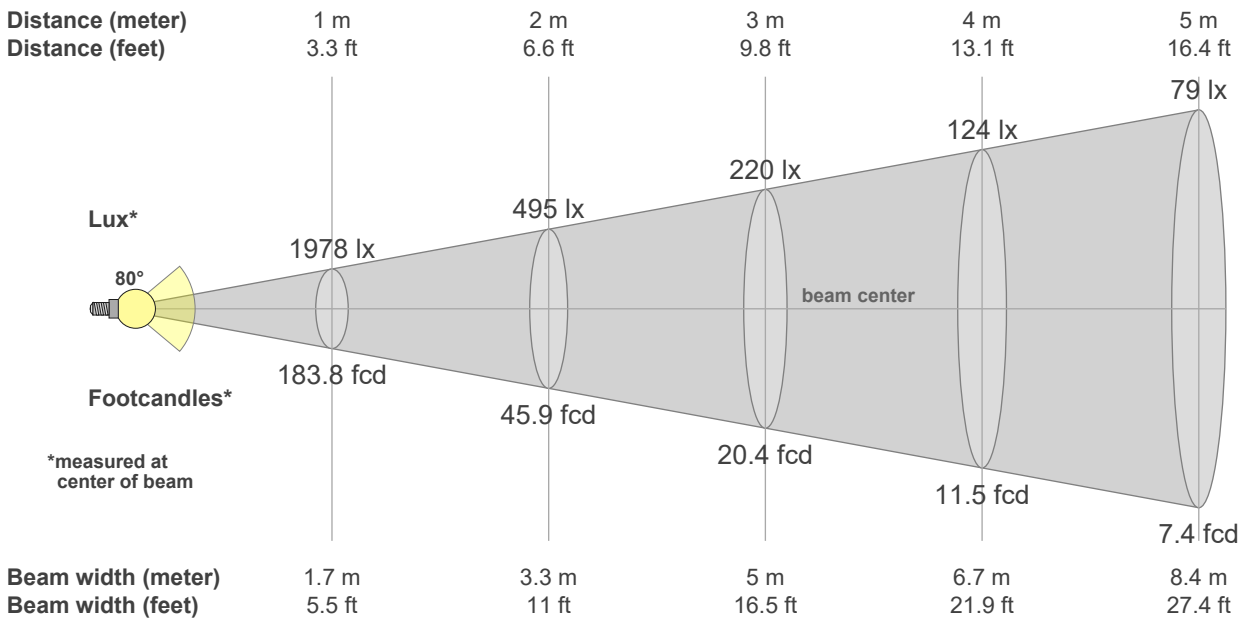
C000-C180
C090-C270

Beam intensities from 1 – 20m

1	2	3	4	5	6	7	8	9	10	11	12	13	14	15	16	17	18	19	20	m
3.3	6.6	9.8	13.1	16.4	19.7	23	26.2	29.5	32.8	36.1	39.4	42.7	45.9	49.2	52.5	55.8	59.1	62.3	65.6	ft
1978	495	220	124	79	55	40	31	24	20	16	14	12	10	9	8	7	6	5	5	lux
183.8	45.9	20.4	11.5	7.4	5.1	3.8	2.9	2.3	1.8	1.5	1.3	1.1	0.9	0.8	0.7	0.6	0.6	0.5	0.5	fc



Colour Details

Colour Rendering Index (CRI)	Colour Rendering Index R9 Value	Colour Rendering TM30-18
Ra 81.2	R9 = 31.3	R _f 81.9, R _g 99.3

Colour Quality Scale	Correlated Colour Temperature, Target	Correlated Colour Temperature, Measured
CQS = 82.2	CCT = 4000 K	CCT = 3985 K

MacAdam Steps	Colour Coordinates CIE 1931	Colour Deviation from BBL
SDCM = 4.2	(x;y) = (0.381;0.377)	Duv = 0.0050

Colour Rendering Index per reference colour (CIE 1995)

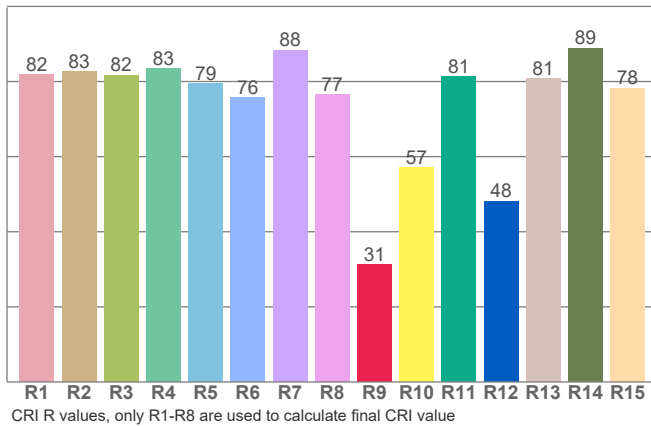

R1	R2	R3	R4	R5	R6	R7	R8	R9	R10	R11	R12	R13	R14	R15
81.8	82.6	81.7	83.5	79.4	75.7	88.3	76.6	31.3	57.0	81.2	48.1	80.8	88.9	78.2

TM30-18 Rf-values per hue bin

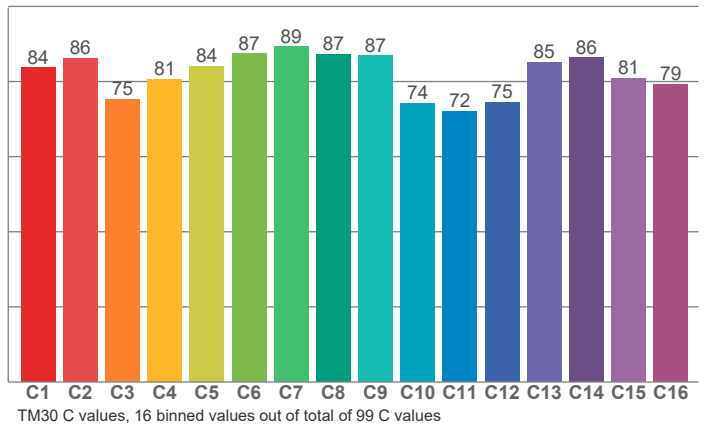

C1	C2	C3	C4	C5	C6	C7	C8	C9	C10	C11	C12	C13	C14	C15	C16
83.7	86.2	75.3	80.6	84.0	87.4	89.3	87.2	86.9	74.2	72.1	74.5	85.1	86.4	80.9	79.3

CIE 1931

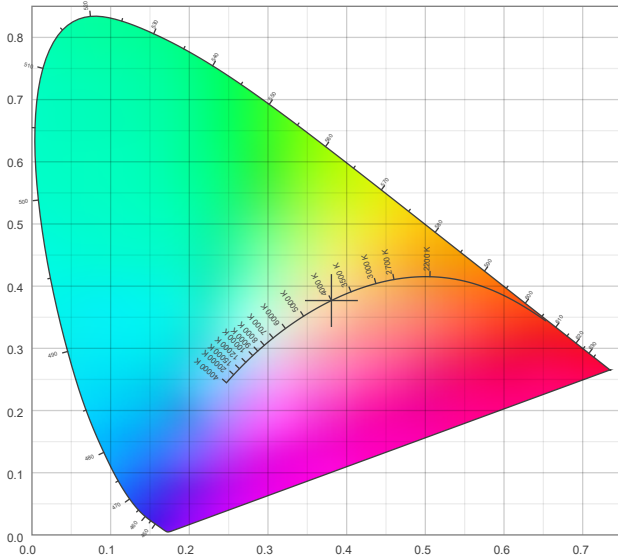

CIE 1931 – Zoomed

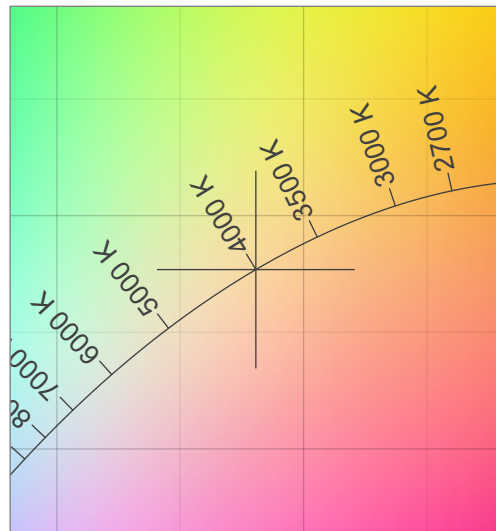

Iso-intensity Diagram (Iso-Candela)

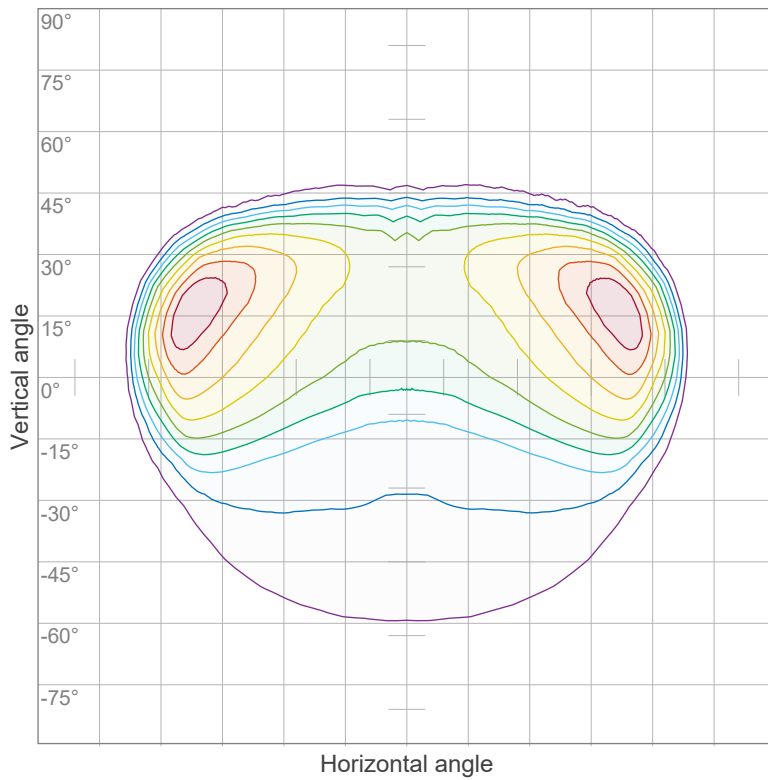

90 %	4102.8 cd
80 %	3647.0 cd
70 %	3191.1 cd
60 %	2735.2 cd
50 %	2279.3 cd
40 %	1823.5 cd
30 %	1367.6 cd
20 %	911.7 cd
10 %	455.9 cd

Peak intensity: 4558.7 cd
Number of c-planes: 72

Iso-illuminance Diagram (Iso-lux)

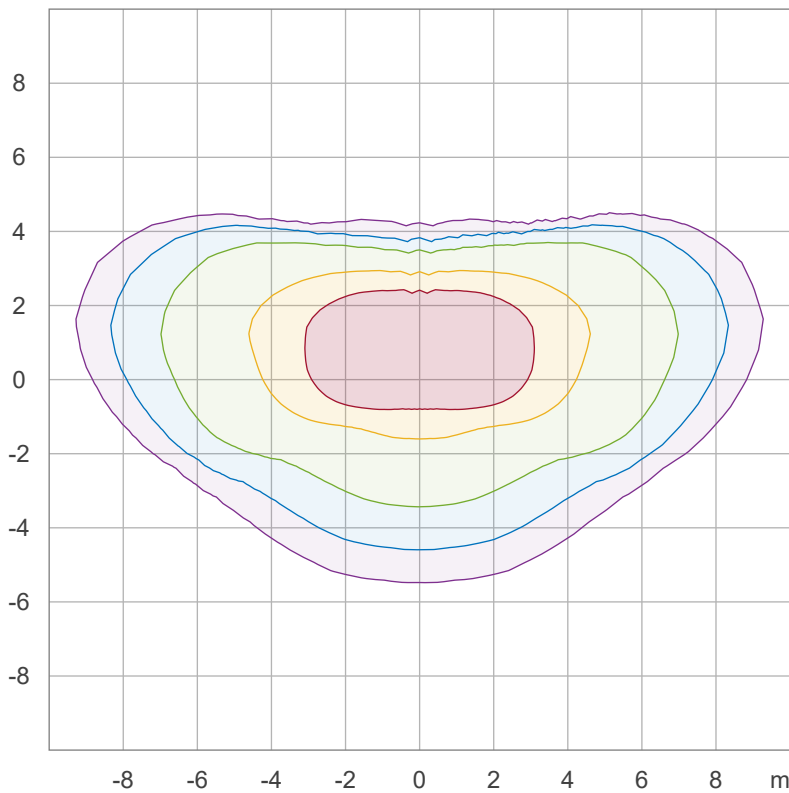

50.0 %	121.4 lx
30.0 %	72.8 lx
10.0 %	24.3 lx
5.0 %	12.1 lx
3.0 %	7.3 lx

Peak illuminance: 242.8 lx
Mounting height: 3.0 m
Number of c-planes: 72



Coefficients of Utilization

Ceiling reflectance	80			70			50			30			10			0		
Wall reflectance	70	50	30	10	70	50	30	10	50	30	10	50	30	10	50	30	10	0
Floor reflectance	20	20	20	20	20	20	20	20	20	20	20	20	20	20	20	20	20	0
RCR	(RCR: Room Cavity Ratio)																	
	Room Values are expressed as percentage of Lumen delivered to the task surface																	
0	119	119	119	119	116	116	116	116	111	111	106	106	106	102	102	102	100	
1	109	104	100	96	106	102	98	95	98	95	92	94	91	89	90	88	84	
2	99	90	83	77	96	88	82	77	85	79	75	81	77	73	78	75	69	
3	89	78	70	63	87	77	69	63	74	67	61	71	65	60	68	63	57	
4	81	68	59	52	79	67	59	52	64	57	51	62	56	50	60	54	47	
5	74	60	51	44	72	59	50	44	57	49	43	55	48	43	53	47	40	
6	68	54	44	38	66	53	44	37	51	43	37	49	42	37	47	41	34	
7	62	48	39	33	61	47	39	32	46	38	32	44	37	32	43	37	30	
8	58	44	35	29	56	43	34	28	41	34	28	40	33	28	39	33	26	
9	54	40	31	25	52	39	31	25	38	30	25	37	30	25	36	29	23	
10	50	36	28	23	49	36	28	23	35	27	22	34	27	22	33	27	20	

